

# FGV-HXY Digital Force Gauge

## Operation Manual

Do not operate or store instrument in the following locations:

Explosive areas, near water, oil, dust or chemicals; areas where the temperatures can exceed 104°F (40° C)

Take precaution to not drop the force gauge. Damage to the sensor may occur.

Do not modify, disassemble or attempt to repair the unit. Send to the factory for proper repair.

If upon delivery damage to the unit is detected, do not operate the unit. Notify the shipping carrier immediately to obtain damage claim instructions.

Only measure forces that are in line with the measuring shaft. Do not attempt to take any measurements (tension or compression) at any angle. Failure to keep measurements in line will damage the instrument.



### Warning



High Capacity Digital Force Gauges with 180° reversible display & dual labeled keypad for both push, pull applications. The Series FGV-HXY Digital Force Gauges offer an enhanced heavy-duty housing allowing them to be utilized in high capacity tension and compression applications. These instruments are utilized in a variety of applications such as, incoming quality inspection, finished goods testing, R&D or almost any portable or force stand testing requirement.

Models are available in 500 lb or 1000 lb ranges providing necessary performance for high capacity testing.

The 180° reversible display combined with the adjustable force direction and dual labeled keypad enable these units to excel in both compression and tension applications in any direction. FGV models possess onboard statistical calculations and provide fast access to maximum, minimum, average and standard deviation data. Models include the free Toriemon software and USB cable allowing further data analysis on a PC. The FGV-HXY's 1,000 point memory allows for data exporting in real time or after testing is complete. In addition, the RS-232C, USB and analog outputs provide maximum communication flexibility.

**Capacity:** -500HXY: 500 lb, 250 kg, 2500 N; -1000HXY: 1000 lb, 500 kg, 4448 N

**Resolution:** 0.1 lb/0.1 kg/1 N

**Accuracy:** ±0.2% F.S.

**Display:** Four digit LCD, .47" high (12 mm) with various indicators including tension and low battery indication (reversible) Minus sign for tension

**Average/Peak Mode:** Selectable

**Display Update:** 0.05, 0.1, 0.2, 0.3, 0.5, 1 sec

**Sampling Rate:** 1000 Hz

**Overload Capacity:** 150% of F.S.

**Power:** Rechargeable Ni-Cad batteries (included) or AC adapter/charger (included)

**Auto Power Shut-Off:** Yes (not active if adapter/charge is in use)

**Battery Charge:** 17 hours (when fully charged)

**Recharge Time:** Approximately 18 hours (when fully discharged)

**Temperature Range:** 32 - 104°F (0 - 40°C)

**Dimensions:** 8.43" x 3.23" x 2.25" (214 x 82 x 57 mm)

**Product Weight:** Approx. 2 lb (900 g) for 500 lb range; 2.65 lb (1.20 kg) for 1000 lb range

**Package Weight:** Approx. 7.45 lb (3.38 kg) for 500 lb range; 8.25 lb (3.74 kg) for 1000 lb range

**Certification:** CE, RoHS

**Warranty:** 2-Year

**Included Accessories:** AC adapter/charger, carrying case, 2 handles, metric thread to inch adapter and attachments (flat head, hook, chisel, notched head, cone head, extension rod), USB cable. Note: software available at [www.shimpoint.com](http://www.shimpoint.com) for free download

**SEALS USA, Inc.**

**Instruments Division**

**Tel: (630)924-7138**

**Email: [support@seals-usa.com](mailto:support@seals-usa.com)**

**Safety Precaution** \*Retain this manual for future reference



It is extremely important for safety that all warnings and cautions are observed exactly per this manual.



**Warning** Serious injury or possibly even death may result if the gauge is used wrongly



**Caution** A serious problem or issue may result if the gauge is used wrongly

**Safety Precaution Symbols**



Warning



Prohibited



Must follow



**Warning**



Take precaution to potential flying parts of test subject upon destruction

When performing a break or failure test, flying parts of the test subject may cause injury. A mask or safety glasses are required for proper safety



Do not use damaged or deformed hook.

If deformed or damaged in any manner, the hook could slip and cause damage upon testing



**Caution**



Do not load above the rated capacity. The sensor could be damaged if overloaded, additional loading above capacity could cause severe damage or an accident



When OVR is displayed, an overload condition has occurred. Reduce the load immediately. Values measured during an overload condition are not accurate.



**Caution**



Please use only supplied AC adapter for charging. If you use a substitute power adaptor, potential product damage or fire may result



Only use 100-230 VAC power voltage. Using power outside this range can cause electric shock or fire



Please plug the AC adapter in firmly. If loose, short circuit or electric shock may result



Do not touch the AC adapter with wet hand. There is the possibility of electric shock.









Do not take apart, make alternations or attempt to repair the FGV. The warranty will be voided and personal injury may result





Do not pull the cord to unplug the AC adapter. The cord may be damaged from improper use and a fire hazard may result

# Safety Precaution

 <b>Caution</b>	
 <p>Do not use AC plug covered with dust.</p> <p>A potential fire hazard may exist</p>	 <p>Do not use and keep FGV under the following circumstances.</p> <ul style="list-style-type: none"> <li>• Location which will be gotten water</li> <li>• Location which will be gotten oil and chemical</li> <li>• Locations which receive direct sunlight</li> <li>• Corrosive and Flammable gas environment</li> <li>• Dew condensation place</li> </ul>
 <p>To clean the FGV do not use a volatile chemical such as benzene, thinner or alcohol. Only use a dry soft cloth or a cloth soaked in a mild detergent that is mixed with water.</p>	 <p>Please use the FGV in operating temperature in range 32 - 104°F (0 - 40°C).</p> <p>If you use FGV beyond above temperature, FGV might operate unusual.</p>
 <p>Accuracy performance degrades overtime. It is recommended the force gauge be checked for performance regularly. The frequency of the checks is dependent on the frequency of use and loading.</p>	 <p>Please operate the force gauge within operating humidity range; 35-85% RH.</p> <p>If you use the force gauge beyond the above range, it might produce improper operation.</p>

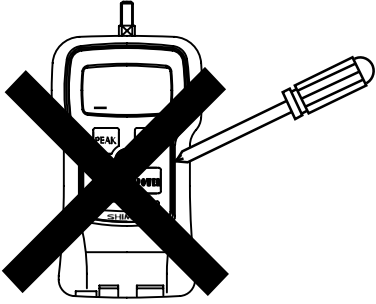
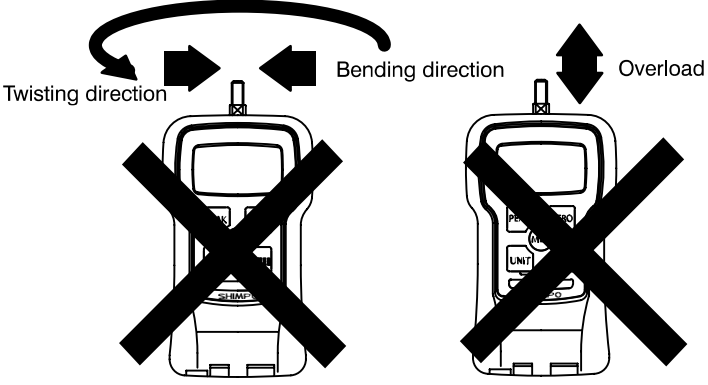
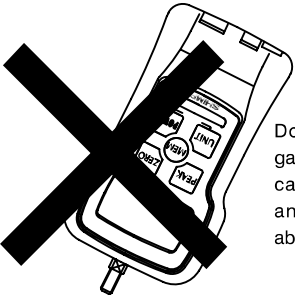
## Caution before use.

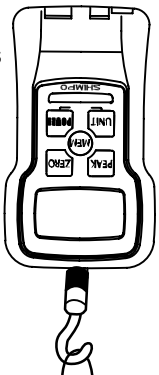
 <b>Caution</b>	
<p>1. Do not press the button with a sharp-pointed object.</p> 	<p>2. Do not load in an axial direction</p>  <p>The FGV can measure pulling and compression loads, but not loads in a rotational direction. The FGV is equipped with a limit stopper. However, this is unable to prevent damage from a heavy impact load or excessive axial forces.</p>
<p>3. Do not drop the force gauge.</p>  <p>Do not allow the force gauge to fall. The sensor can become damaged and will no longer be able to perform properly.</p>	<p>4. Do not use the force gauge in locations where it may get wet.</p>  <p>This force gauge is not water proof. Please do not operate the force gauge in locations where it may get wet.</p>
<p>5. Measuring very small loads</p> <p>Factory default, the tracking setting is set to ON. When measuring small loads, turn the tracking setting to OFF. Refer to Tracking Section for further details.</p> 	

# INDEX

<u>1. Product Features</u>	4	6.7. Recalling memory data	19
<u>2. Included Accessories</u>	4	6.7.1. Continuous memory mode	19
<u>3. Product Diagram</u>	5	6.7.1.1. Measuring memory data	19
3.1. Main unit	5	6.7.1.2. Statistics memory data	20
3.2. Display Outline	6	6.7.2. Single memory mode	21
3.2.1. Numeric display	6	6.7.2.1. Measuring memory data	21
3.2.2. Unit display	6	6.7.2.2. Statistics memory data	22
3.2.3. Peak hold display	6	6.7.3. Standard memory mode	23
3.2.4. MAX/MIN display	6	6.7.3.1. Measuring memory data	23
		6.7.3.2. Statistics memory data	24
<u>4. Before use</u>	7	6.8. Erasing memory data	24
4.1. Charge	7	6.8.1. Erasing last data point	24
4.2. Attaching measuring adapter	7	6.8.2. Erasing all memory data	25
4.3. Attaching hanger	7	6.8.3. No memory data	25
4.4. Attaching of the Handle	7	6.9. USB Communication	25
4.5. Tracking	8	6.9.1. Feature of ToriemonUSB	25
4.6. Reverse the display	8	6.9.2. Download ToriemonUSB	25
		6.9.3. Precaution when using USB communication	25
<u>5. Function setting</u>	9	<u>7. External Connection</u>	26
5.1. Sign: f01	9	7.1. Pin assignment	26
5.2. Display update time: f02	10	7.2. RS-232C output	26
5.3. Auto power off: f03	10	7.2.1. RS-232C interface	26
5.4. Baud rate of RS232C: f04	10	7.2.2. RS-232C communication command	27
5.5. Response Time: f05	11	7.2.3. Connection between FGV and PC	28
5.6. External output: f06	11	7.3. Analog output	28
5.7. Peak signal mode: f07	12	7.4. Overload/Comparator output	28
5.8. Function mode-end	12	<u>8. Signal Connector</u>	29
<u>6. Feature and Operation</u>	12	8.1 Pin assignment	29
6.1. Overview of operation	12	8.2 Mitutoyo digimatic output	29
6.2. Measuring mode	13	8.3 Comparator output	29
6.2.1. Standard measuring mode	13	8.4 External input signal	30
6.2.2. Peak hold mode	13	<u>9. Frequently-asked questions</u>	31
6.3. Change display unit	13	9.1. Troubleshooting	31
6.4. Tare	13	9.2. Technical issue	31
6.5. Comparator	14	<u>10. Support</u>	31
6.5.1. Comparator	14	10.1. Repair and Calibration	31
6.5.2. Enter Comparator/Memory setting mode	14	10.2. Warranty	31
6.5.3. Setting HI limit	14	<u>11. Dimensions</u>	32
6.5.4. Setting LO limit	15		
6.5.5. Comparator Judgment Display	15		
6.5.6. Judgment Signal	15		
6.6. Memory	15-16		
6.6.1. Setting memory mode	17		
6.6.2. Storing data	18		
6.6.2.1. Continuous memory mode	18		
6.6.2.2. Single memory mode	18		
6.6.2.3. Standard memory mode	18		

## 1.Product Features

- Nickel-hydrogen battery for long time use: 4.1. Charge
- Data can be downloaded to PC with USB: 6.9. USB communication
- 1000 data point memory: 6.6. Memory
- Comparator shows pass or fail. ( I/O output of the result): 6.5. Comparator
- Reverse the display of the measuring value and the unit.: 4.6. Reverse the display
- One touch simple operation for changing the unit N, kg(g), Lb(oz).: 6.3. Change display unit
- Measure peak value (positive or negative): 6.2.2. Peak hold mode
- Display update time is selectable up to 20 times/second.: 6.2.1 Standard measuring mode
- External tare signal, display value hold, PEAK mode changeover feature: 8.4 External input signal
- Available measuring data output with Mitutoyo Digimatic communication: 8.2 Mitutoyo Digimatic output

## 2.Included Accessories

- Before use, please confirm the following items are included in the carrying case.

1. Main Unit



3. Instruction manual



4. Measuring adapters



Hook

M10



Flat head  
ø24



Cone head  
90°



Notched head  
90°



Chisel  
90°

2. AC adapter

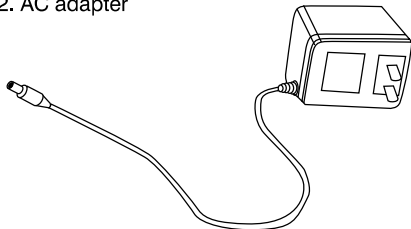

Extension rod L:112(M10)

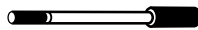

5. Hanger



6. USB cable (2.0)

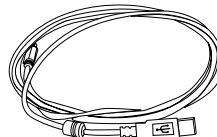

7. Handle

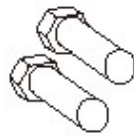

## 3. Product Diagram

### 3.1.Main Unit

FGV-500/1000HXY

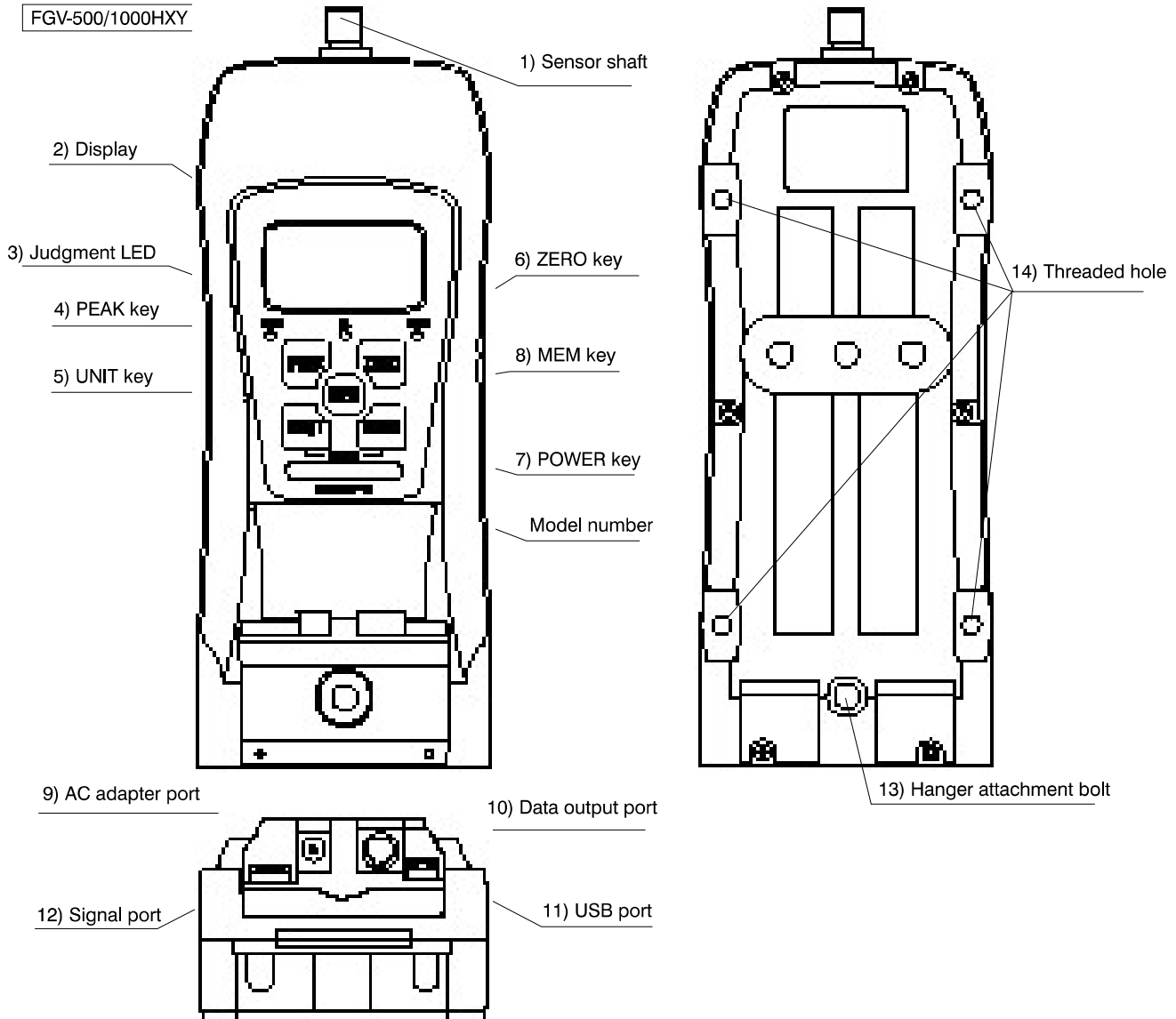

1	Sensor shaft	Force bolt (Push/Pull force)
2	Display	Display the load and the unit
3	Judgment LED	Light on the LED as the result of comparator judgment
4	PEAK key	<ul style="list-style-type: none"> <li>• Switch the mode (standard measuring mode; +peak hold mode; -peak hold mode)</li> <li>• Tracking ON/OFF</li> <li>• It is used for comparator/memory setting</li> </ul>
5	UNIT key	<ul style="list-style-type: none"> <li>• Switch the unit (N; Kg; lb(oz); N)</li> <li>• It is used to reverse the display.</li> <li>• Tracking ON/OFF.</li> <li>• It is used for comparator/memory setting.</li> </ul>
6	ZERO key	<ul style="list-style-type: none"> <li>• Tare at standard measuring mode (not display a peak value).</li> <li>• It is used for function setting.</li> <li>• Press the ZERO key under the peak hold mode (display the peak value), to clear the peak value. In this case, tare does not perform. If you need tare, press the peak key to change into standard measuring mode, then press the Zero key.</li> <li>• It is used for comparator/memory setting.</li> </ul>
7	POWER key	<ul style="list-style-type: none"> <li>• Press the POWER and release to turn ON/OFF.</li> <li>• It is used to reverse the display.</li> <li>• Tracking ON/OFF.</li> <li>• It is used for comparator/memory setting.</li> </ul>
8	MEM key	<ul style="list-style-type: none"> <li>• Press the MEM key under the standard measuring mode (not display peak value), then measuring value is memorized.</li> <li>• It is used to recall the memory data, and setting High/Low limits.</li> <li>• It is used for comparator/memory setting.</li> </ul>
9	AC adapter port	Supply the electricity through the AC adapter.
10	Data output port	Connect with a PC and a recorder. (RS232C, analog output and so on)
11	USB port	Connect with a PC. (USB)
12	Signal port	Signal port for comparator output, input signal and Mitutoyo Digmatic signal
13	Hanger attachment bolt	Attach the hanger with this bolt.
14	Threaded hole	Use this threaded hole in order to attach the FGV with a stand.

## 3.2.Display Outline

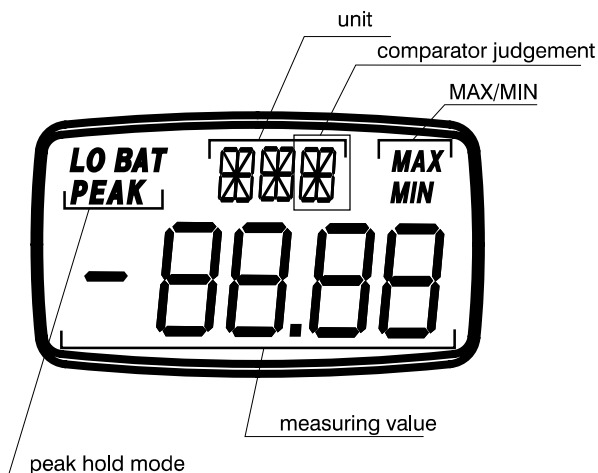

### 3.2.1.Numeric Display

Display the measuring value with sign and 4 digits numbers. Compression force: plus, Tension force: minus. (It's available to switch plus/minus with the setting of function (f01)). Reverse display is available.

### 3.2.2.Unit Display

Display the units. In case of overload, "OVR" is shown. "PWR" appears to notify that there is 1 minute before power off.

Display of unit

Newton <i>N</i>	Kilogram <i>kg</i>	Gram <i>g</i>	Pound <i>lb</i>	<i>N</i> Δ

Kg/g, lb/oz are decided by rating capacity.

Overload 1 Minute before power off.

Reverse display is available.

"HLD" is displayed when HOLD signal is ON.

"▽" or "△" are shown when comparator feature is ON. See 5.5.5. Judgement on LCD.

### 3.2.3.Peak hold display

Depend on the condition of the force gauge, the following display is shown.

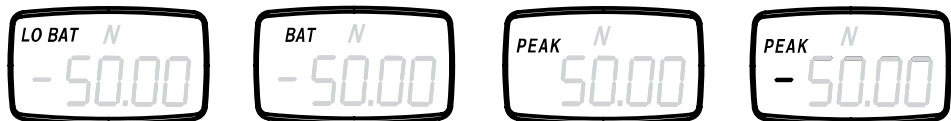

In case of the voltage of internal nickel hydride battery decreases, "LO BAT" turns on and off. Please connect AC adapter to charge the battery.

During the charge of battery, "BAT" is shown. Even if turn the power off during the charge, "BAT" will be displayed.

"PEAK" turns on when plus peak hold mode.\*

"PEAK" turns on when minus peak hold mode.\*

\*Please discern plus peak hold mode and minus peak hold mode with or without "-".

### 3.2.4.MAX/MIN display

In case of showing statistical data for memory mode (continuous, single, standard), the following displays are shown.

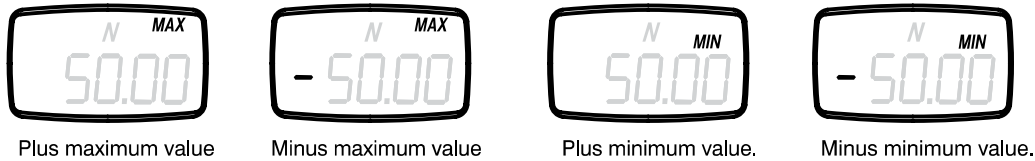

## 4. Before use

### 4.1. Charge



Only charge with supplied AC adaptor.

Please use AC adaptor supplied with the FGV. An alternate adaptor could cause damage and fire.

The unit's battery may be depleted upon first use. Plug attached AC adaptor and charge before you use.

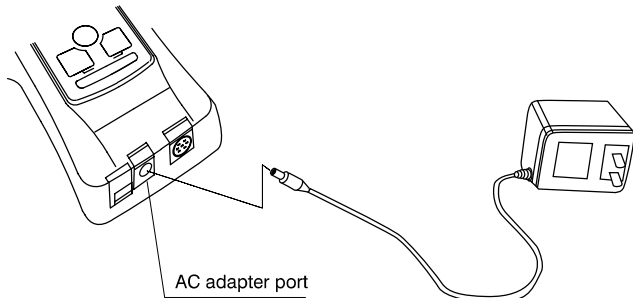

1. Please connect the attached AC adapter into the AC adapter port of the body, and then plug the adaptor into an outlet
  - Charge the battery. After charging is complete, the charging automatically stops. • "BAT" will be shown on the LCD display while charging. After complete the charging, "BAT" will disappear from LCD.
  - Charge time: Up to 16 hours at most.
  - Operating time: Approx. 8 hours per 1 full charge.
2. The nickel hydride battery is charged automatically when it is discharged during the usage of AC adapter.
  - \*If you charge the battery frequently, its lifetime will be shortened. When you use the FGV with AC adapter, you should not insert and remove the AC adapter often.
3. Measurements may be taken during charging
4. After the battery power has declined, "LoBAT" appears on the display. Connect the AC charger. If you leave the gauge turned on while "LoBAT" is displayed, the power will continue to decline and the unit will automatically shut off.

### 4.2. Attaching measuring adapter

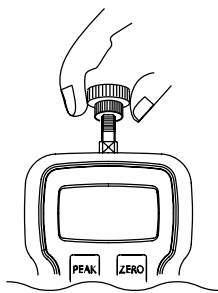

Please select the measuring adapter depending on the measuring purpose. Screw the adapter until it stops lightly. Do not screw it forcibly in order not to give the damage to the sensor.



Do not screw the adaptor on too tightly as it could damage the sensor.



Do not use scratched hook or deformed hook.

Hook



Flat head



Cone head



Notched head



Chisel



Extension rod

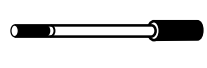

### 4.3. Attaching hanger

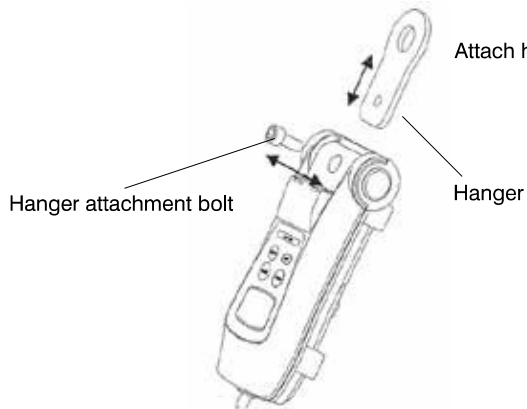

\* Please use a tolerable nail or winch against the load .

Please take off the attached hanger bolt. Fit the square hole of hanger into the salient part of the case, and then tighten the attached hanger bolt.

### 4.4 Attaching of the handle

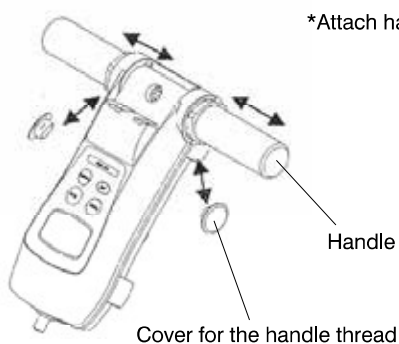

When testing by hand, to record the most stable force, it is recommended to use the attachment handle.



\*Only use the attachment handle when testing by hand.

## 4.5. Tracking

A load cell strain gauge is used for the FGV force sensing. This type of sensor can alter its output due to changes in temperature. The tracking feature algorithm can negate this slight change. When measuring very small forces, an error could arise while tracking is on. It is recommended on light load sensing to turn the tracking function off. To turn the tracking off, hold the PEAK key and UNIT key simultaneously while the power is off. Next, press and release the POWER key. Then, release the PEAK key and UNIT key after a value has remained on the screen for 1 second.

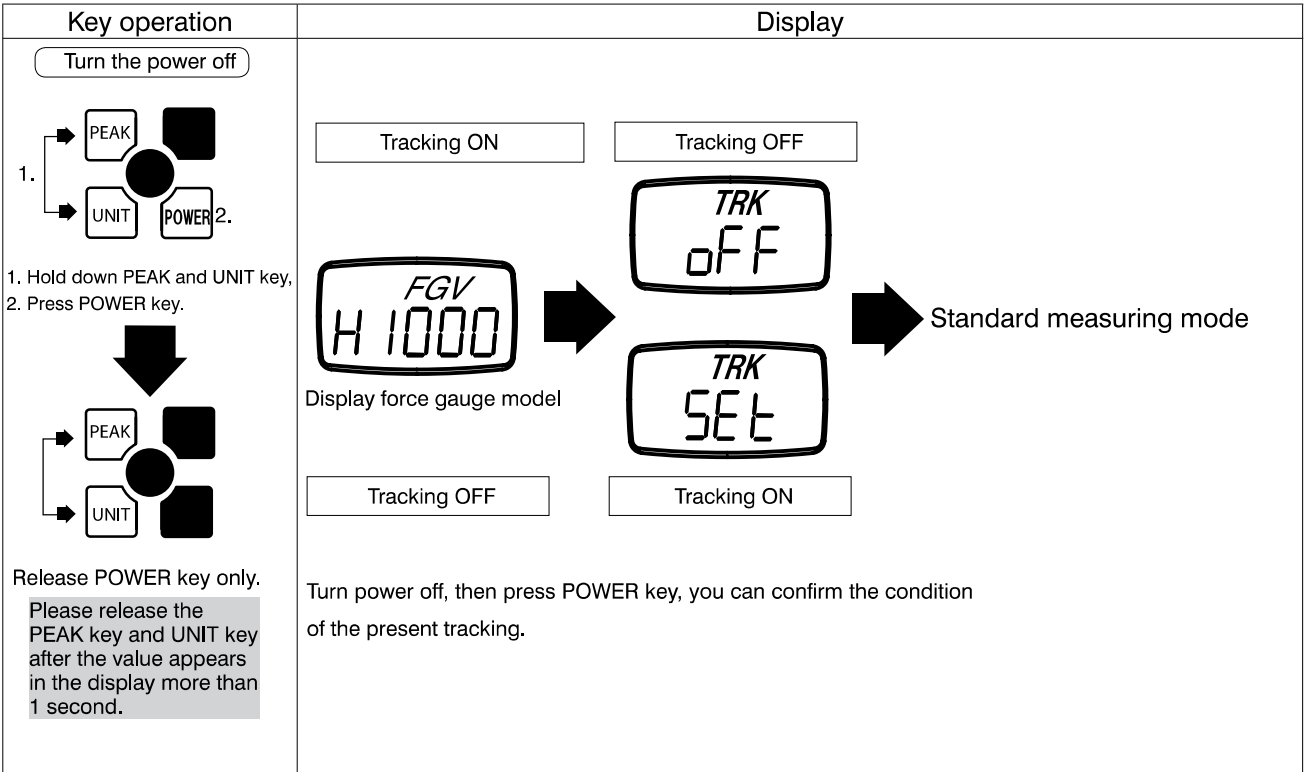

## 4.6. Reverse the display

In the case you attach FGV with a stand, display of the value and the units can be reversed in order to read the display easily. Turn POWER off. Press the UNIT key and hold, then press POWER key and release (release UNIT key after the value appears in the display more than 1 second). Then you can reverse the display.

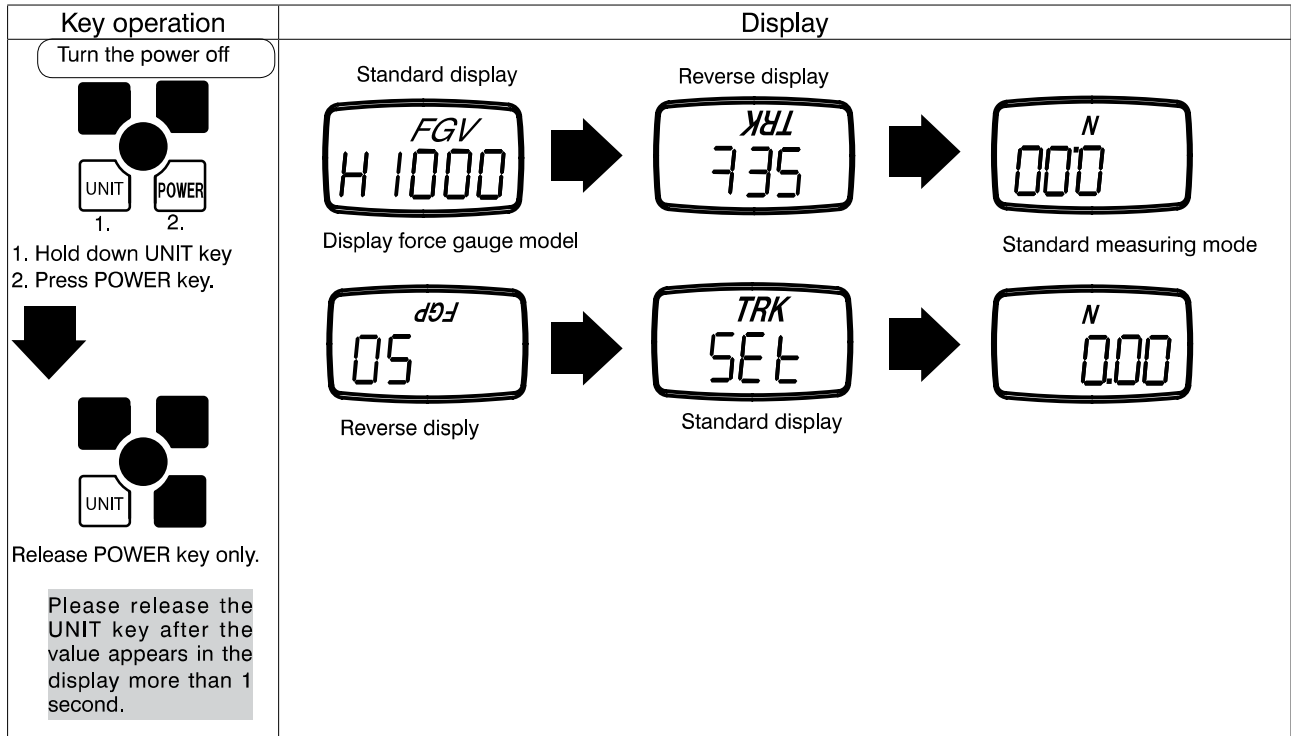

## 5.Function setting

The following setting items in function mode.

Item	Unit	Set contents	Default factory setting
Display sign	f01	-0001(minus), 0001 (plus)	0001
Display update time	f02	1, 2, 3, 5, 10, 20 (times/second)	3
Auto power off	f03	10 (10 minutes), oFF (not valid)	10
RS-232C baud rate	f04	2400, 4800, 9600, 19200 (bps)	2400
Response Time	f05	3, 20, 150 (msec)	3
External output	f06	ovEr, Hi-Lo	ovEr
PEAK signal mode	f07	nonE, +PEAK, -PEAK	nonE

Key operation	Display
<p>Turn the power off</p> <p>1. Hold down ZERO key, 2. Press POWER key.</p> <p>Release POWER key only. Please release the ZERO key after the value has appeared in the display more than 1 second.</p>	<p>Display force gauge model      Display function mode (f01)</p>



### 5.1.Sign: f01

The measuring values of the sensor may be set to have a plus or minus sign.  
Select the sign by pressing of UNIT key / Press the PEAK key to move ahead.

Key operation	Display
<p>Each time to press UNIT</p>	<p>Minus      Plus</p>
	Register all settings, and then move to the standard measuring mode.
	Reserve the change, and then move to f02.

## 5.2. Display update time: f02

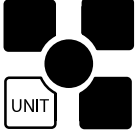
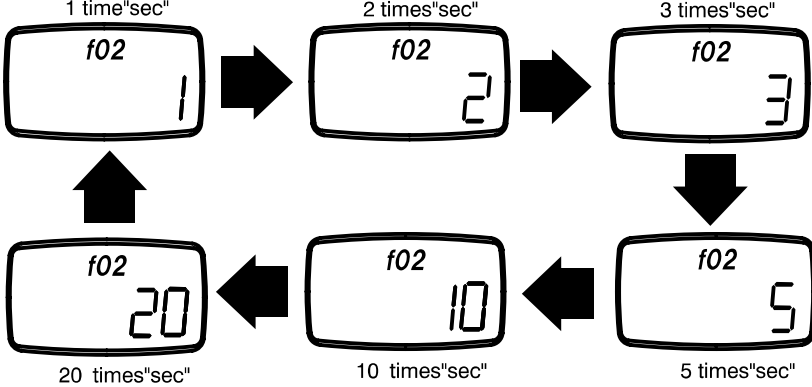
It's available to set the display update time for 1 time/second, 2 times/second, 3 times/second, 5 times/second, 10 times/second and 20 times/second. After the setting, the averaging value within display update time is shown every display update time. Press the UNIT key to choose the display update time (1, 2, 3, 5, 10, 20 (times/second)). Press the PEAK key to move ahead.



Key operation	Display
 Press UNIT to cycle through settings	
	Save current setting and return to the standard measuring mode.
	Save the change and then move to f03.

## 5.3. Auto power off: f03

If the gauge is on and there is no activity for 10 minutes\*, the unit automatically powers off to conserve battery charge (When connected with the AC adapter, the Auto Power off function does not work.). "PWR" appears to notify that there is 1 minute before power off.

Press the UNIT key to switch the auto power off, Press the PEAK key to move ahead

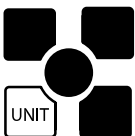
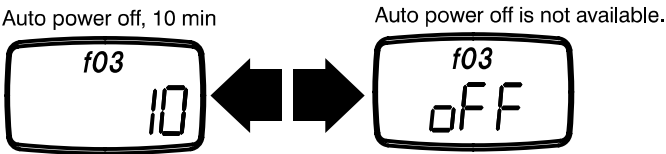

\*No activity means there is no key operation, RS-232C communication, USB communication, or no change of measuring value.

Key operation	Display
 Press UNIT to cycle through settings	
	Save current setting and return to the standard measuring mode.
	Save the change and then move to f04.

## 5.4. Baud rate of RS-232C: f04

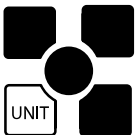
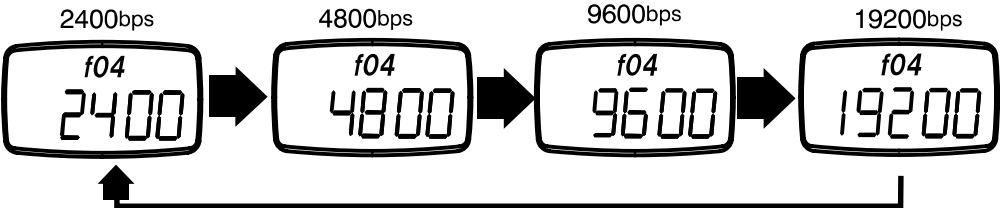

It's available to set the baud rate of RS-232C.

Press the UNIT key to switch the Baud rate (2400, 4800, 9600, 19200(bps)) \* Press PEAK key to move ahead.

Key operation	Display
 Press UNIT to cycle through settings	
	Save current setting and return to the standard measuring mode.
	Save the change and then move to f05.

## 5.5. Response Time: f05

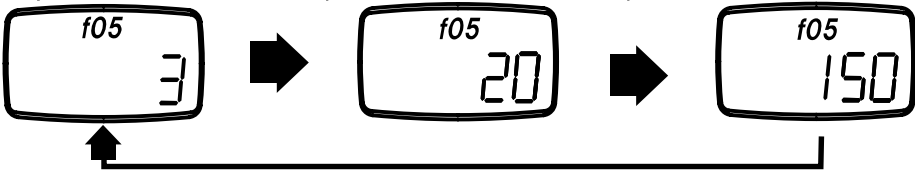
The response time function smooths out the gauge's sampling, and adjusts the sampling period accordingly. The available response times are 3, 20, and 150 msec. Press UNIT to change the setting, PEAK to save and move to the next function, or ZERO to save and finish.

Key operation	Display
 <p>Press UNIT to cycle through settings</p>	<p>Response time 3msec    Response time 20msec    Response time 150msec</p> 
	Save current setting and return to the standard measuring mode.
	Save the change and then move to f06.

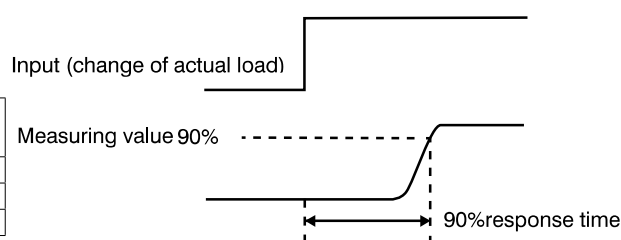

\* Filter response time show 90% of step input. Depend on the filter response, sampling period and analog output update period is decided.

Filter response	Sampling period • Analog output update period
3msec	1msec
20msec	1msec
150msec	6.7msec



## 5.6. External output : f06

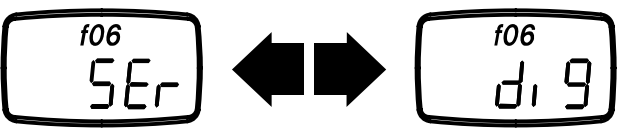

It's available to change the external output; RS-232C, USB and Digimatic output. Press UNIT key to switch the external output. Press PEAK key to save and move to next function.

Key operation	Display
 <p>Press UNIT to cycle through settings</p>	<p>RS-232C • USB output    Digimatic output</p> 
	Save current setting and return to the standard measuring mode.
	Save the change and then move to f07.

## 5.7 PEAK signal mode: f07

It's available to set PEAK signal mode.

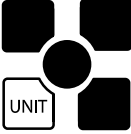
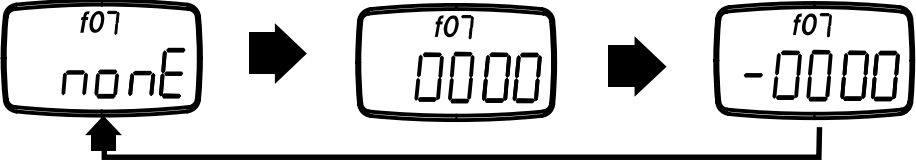
Press the UNIT key to switch the PEAK signal mode. Press PEAK key to go back to f01.

Key operation	Display
 <p>Press UNIT to cycle through settings</p>	<p>Not available PEAK signal      PEAK signal mode: +PEAK      PEAK signal mode: -PEAK</p> 
	Save current setting and return to the standard measuring mode.
	Save the change and then move to f01.

## 5.8. Function mode-end

Press ZERO key to memorize the set value and come back from function mode to standard measuring mode.

In order to cancel the change of function mode, press POWER key, then turn the POWER off.

## 6. Feature and Operation

### 6.1. Overview of operation

#### 1. Basic operation

Key	Operation
POWER	Turn the POWER ON/OFF
ZERO	Tare (Peak reset at the PEAK Hold mode)
PEAK	Standard measuring mode / Plus peak hold mode / Minus peak hold mode
UNIT	Change the unit
MEM	Store the measuring data into memory

#### 2. Special operation

Key	Operation	How to operate
PEAK + UNIT POWER	Tracking ON / OFF	Turn POWER off. Press PEAK key and UNIT key simultaneously and hold, then press and release POWER key (release the PEAK key and UNIT key after the value appears in the display more than 1 second.)
ZERO + POWER	Function mode	Turn POWER off. Press ZERO key and hold, then press POWER key and release (release ZERO key after the value appears in the display more than 1 second). Function mode; UNIT: Change the setting content PEAK: Switch the function ZERO: Register the setting content
UNIT + POWER	Reverse display	Turn POWER off. Press UNIT key and hold, then press POWER key and release (release the UNIT key after the value appears in the display more than 1 second.)
MEM + POWER	Display memory data	Turn POWER off. Press MEM key and hold, then press POWER key and release (release MEM key after the value appears in the display more than 1 second.) Display memory data; UNIT: Display the statistical data PEAK: Memory data display end ZERO: Delete one memory data Hold ZERO key to delete all data MEM: Next memory data
PEAK + POWER	Comparator memory mode setting	Turn POWER off. Press PEAK key and hold, then press POWER key and release. In this setting; UNIT : Change sign, number and memory mode PEAK : Change the setting content ZERO : Shift the digit MEM : Register the setting content

## 6.2.Measuring Mode

Standard measuring mode or peak hold modes are available.

### 6.2.1 Standard measuring mode

It's available to measure the compression and tension force. Measuring value appears at all times.

1. Press POWER key and release ( Turn POWER on after release)
2. Press ZERO key to tare.

Displayed measuring value is the averaged out sampling value (every 1 msec\*) per display update time.

Display update time of default factory setting is 3 times/second. In order to increase the display response against the change of measuring value, you may change the set value of display update time.

You can increase this time up to 20 times/second (regarding the change of display update time, please refer to Display Update Time.)

\*Based on the Response Time (f05) setting.

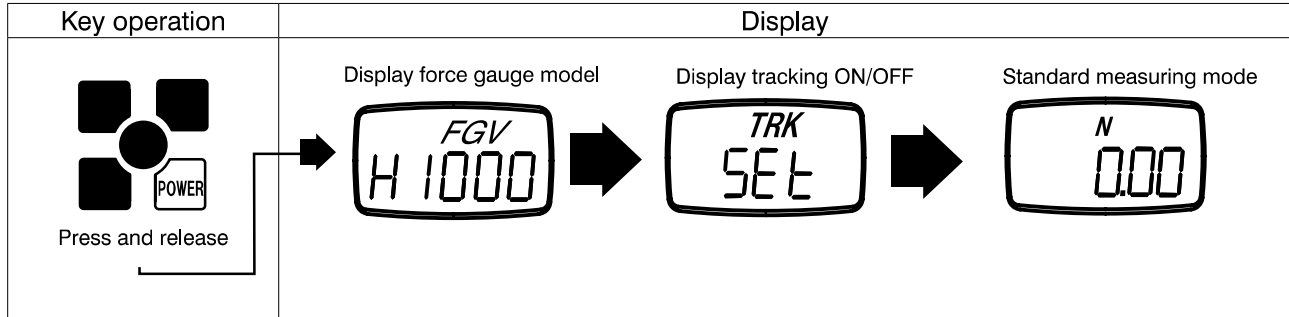

### 6.2.2 Peak hold mode

Peak mode displays the greatest force in both positive or negative directions. Sampling time is 1ms.\*

Press PEAK key to change standard measuring mode, Plus peak hold mode and Minus peak hold mode.

Under the plus peak hold mode, "PEAK" appears.

Under the minus peak hold mode, "PEAK" and "-" (minus) are displayed.

\*Based on the Response Time (f05) setting.

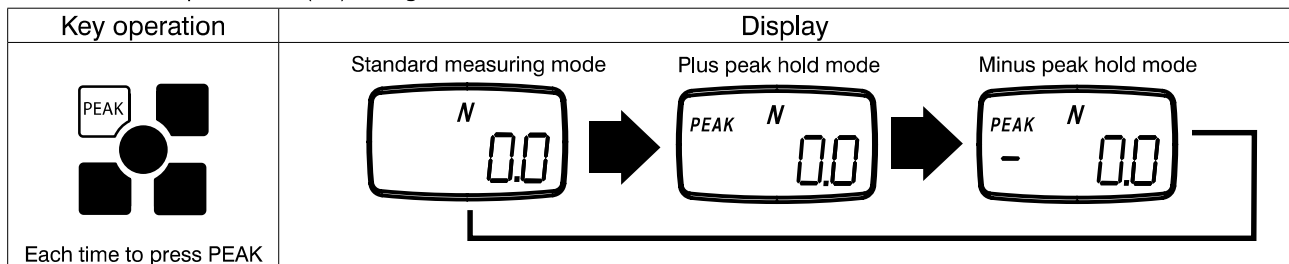

Under the plus peak hold mode and minus peak hold mode, press ZERO key to clear the peak value (Tare is not performed).

## 6.3.Change display unit

To change the display units, just press UNIT and the units will change every time the button is pressed.

N; kg (g); lb (oz); N

## 6.4.Tare

Press ZERO key to reset the measuring value. Please press the ZERO key before starting the measurement in order not to change the starting display value because of the own weight or measuring direction or weight of measuring fixture.

Measuring range is from maximum pulling load to maximum compression load. When measuring range is over the limit, "OVR" is displayed.

Press the ZERO key under the plus peak hold mode or minus peak hold mode. The plus peak value or minus peak value is cleared. In plus peak hold or minus peak hold modes, the tare cannot be performed even when pressing and releasing the ZERO key.

When turning the POWER on, a tare is automatically performed. If you turn POWER on while getting a load force, the display becomes "0" and you cannot measure accurate values.

## 6.5.Comparator

### 6.5.1.Comparator

Compare HI / LO limits which you entered. The results appear on the display. In addition, an output signal of the result is available with the data output port. In order to activate the comparator function, set Hi-Lo at External output (f06) in the function settings. When you set "ovEr" at the External output (f06), a result will not appear and the output signal does not perform.

### 6.5.2.Enter Comparator / Memory setting mode

Turn POWER off, press PEAK key and hold, then press POWER key and release (release PEAK key after the value is displayed more than 1 second).

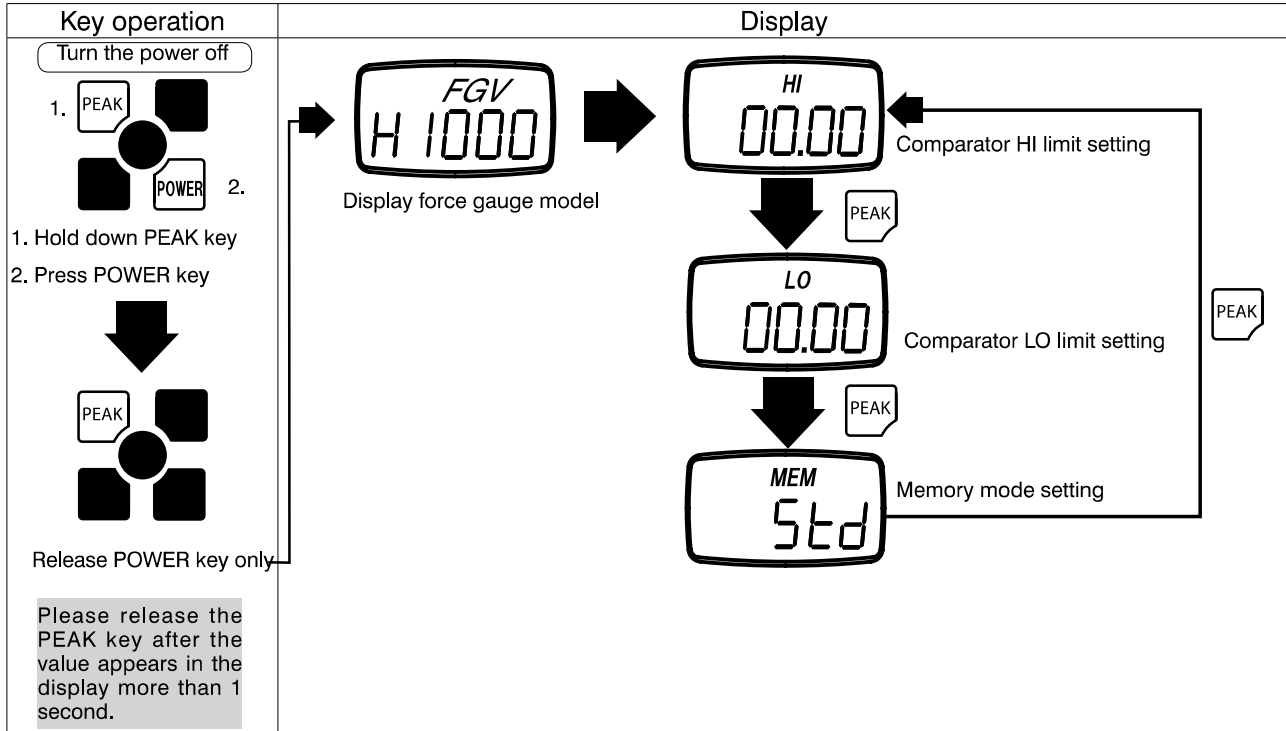

There are following setting items for comparator /memory setting mode.

Item	Display	Content of setting	Default factory setting
Comparator HI limit	HI	Set the comparator HI limit*	0
Comparator LO limit	LO	Set the comparator LO limit*	0
Memory mode setting	MEM	Set the memory mode (single mode, continuous mode, standard mode)	Std

When you set "0" at both HI limit and LOW limit, comparater function does not work.

### 6.5.3.Setting HI limit

- Press the UNIT key then all 4 digits turn on and off. Press the UNIT key once more, you can chose sign (plus or minus).
- Choose 0,1,2,3,4,5,6,7,8,9 at 4 - 1 digit (when you prees UNIT key at 9, it turns 0). Press ZERO key to move right one digit. In this case, chosen number is displayed with unit which is chosen at standard measuring mode. (When you change the unit at standard measuring mode after the setting of HI limit, the conversion of the unit for HI limit value is not performed. After the change of the unit, please set the HI limit again.)
- Press PEAK key, then move to the setting of comparator LO limit
- Press MEM key, then setting value is registerd and move to standard measuring mode.
- When you set both HI and LO limit with "0", comparater function does not work.

#### NOTICE



You can set the value regardless of rating capacity. In the case you set the value which is out of the range for rating capacity, comparator function might not work properly.

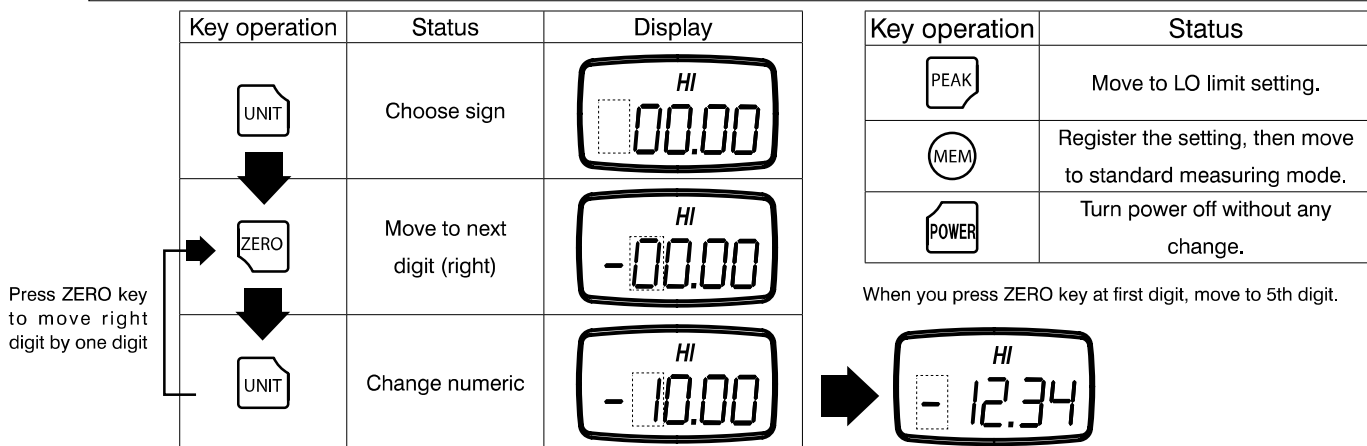

## 6.5.4. Setting LO limit

1. Press PEAK key during comparator HI limit setting, then move to LO limit setting.
2. Setting way is the same as the comparator HI limit setting.
3. Press MEM key, then setting value is registered, and move to standard measuring mode.
4. When you set HI and LO limit with "0", comparator function is inactive.

LO limit setting mode



Key operation	State
	Move to memory mode.
	Register the setting, then move to standard measuring mode.
	Turn power off without any change.

## 6.5.5. Comparator Judgment Display

Compare the measured values to comparator HI / LO limit values. Result displays icons  $\Delta$   $\nabla$  after the unit.

" $\Delta$ " means measuring value > HI limit

" $\nabla$ " means measuring value < LO limit

Relation between judgement and display is as follows.

	Data $\leq$ HI limit Data $\geq$ LO limit	Data > HI limit Data < LO limit	Data $\leq$ HI limit Data $\geq$ LO limit	Data > HI limit Data < LO limit
In case of N (unit)				
LED light on	Hi-NG ● OK ○ Lo-NG ●	Hi-NG ○ OK ● Lo-NG ●	Hi-NG ● OK ● Lo-NG ○	Hi-NG ○ OK ● Lo-NG ○

\*In order to activate the display of comparator judgement, you have to set "Hi-Lo" at function mode "External output (f06)".

## 6.5.6. Judgment Signal

Compare the measured values to comparator HI / LO limit values, then the signal of comparator judgement will be outputted through the data output port.

Measuring value > HI limit value; Turn on output signal of comparator HI limit.

Measuring value < LO limit value; Turn on output signal of comparator LO limit.

\*In order to activate output signal of comparator judgement, please set "Hi-Lo" at function mode "External output (f06)".

## 6.6. Memory

There are 3 modes at memory mode as follows.

Continuous memory	Allows the recording of up to 1000 data points. The recording starts when you push MEM, and stops when you push MEM. In addition, the following statistics, gathered between that start and stop, are recorded: positive maximum value, negative maximum value, positive minimum value, negative minimum value, positive peak value, negative peak value, average value, standard deviation.
Single memory	Allows the recording of up to 100 data points. Every time MEM is pressed, the value shown on the display is memorized. If the unit is in Standard mode then the current measured value is recorded. In Peak mode, the unit records the displayed peak value. In addition, the following statistics are recorded: positive maximum value, negative maximum value, positive minimum value, negative minimum value, average value, standard deviation.
Standard memory	Allows the recording of up to 50 data points. The recording process is similar to Continuous mode. MEM starts the recording, and stops the recording. The measured value, when MEM is pushed the second time, is recorded as a point. The following statistics, gathered between the start and stop, are recorded: positive maximum value, negative maximum value, positive minimum value, negative minimum value.

[Definisions of the terms]

Measuring value: Displayed value which is per display update time at standard measuring mode.

Plus maximum value (+MAX): Maximum value at plus side which is measured within memory measuring interval.

Minus maximum value (-MAX): Maximum value at minus side which is measured within memory measuring interval.

Plus minimum value (+MIN): Minimum value at plus side which is measured within memory measuring interval.

Minus minimum value (-MIN): Minimum value at minus side which is measured within memory measuring interval.

Example of +MAX, -MAX, +MIN, -MIN (Continuous memory mode)

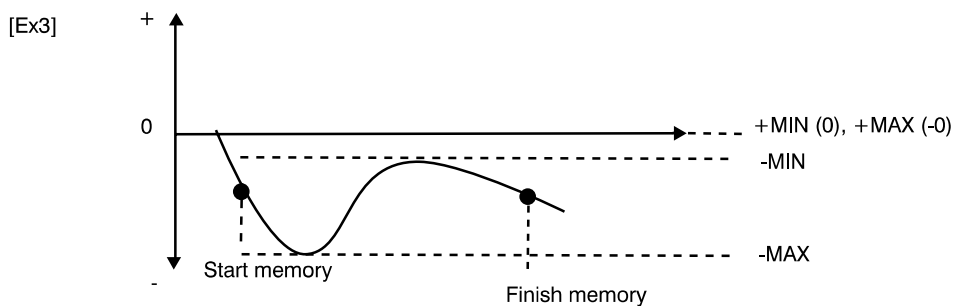
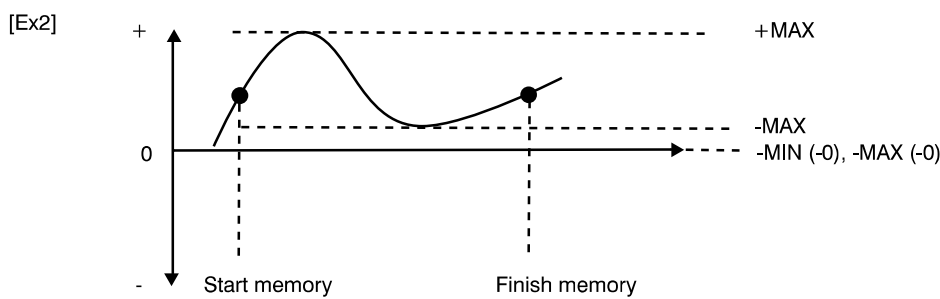
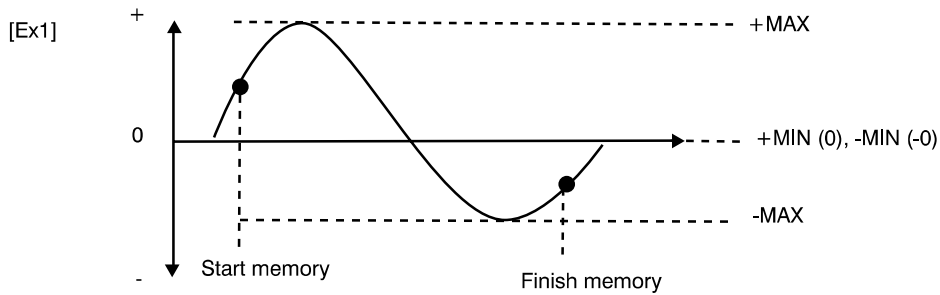

- Average value (AVE) : Average value of measuring value which is measured within memory measuring interval.  $\sum X_i/n$
- Standard deviation (DEV) : Standard deviation of measuring value which is measured within memory measuring interval.  $\sqrt{\sum(X_i-\bar{X})^2/n}$
- Plus peak value : Plus peak value within memory measuring interval (Maximum value within sampling interval 1000 times/second).
- Minus peak value : Minus peak value within memory measuring interval (Minimum value within sampling interval 1000 times/second)
- Last measuring value (LST) : Value which is measured in the end of memory measuring interval.

## 6.6.1. Setting memory mode

Turn the POWER off. Press PEAK key and hold, then press POWER key. Comparator HI limit setting turns on, then press PEAK key twice. Memory setting mode turns on.

There are following setting items for comparator • memory setting mode.

Item	Display	Content	Default factory setting
Comparator HI limit setting	HI	Set comparator HI limit *	0
Comparator LO limit setting	LO	Set comparator LO limit *	0
Memory mode setting	MEM	Set memory mode (Single mode, Continuous mode, Standard mode)	Std

\* When you set "0" at both HI limit and LO limit, comparator function is inactive.

At memory mode setting, you can set single memory, continuous memory, standard memory.

1. Switch memory mode (SinG (single memory mode), Cont (continuous memory mode), Std (standard memory mode)) by UNIT key.
2. Press PEAK key to move comparator upper limit setting.
3. Press MEM key to register the setting and exit to standard display.

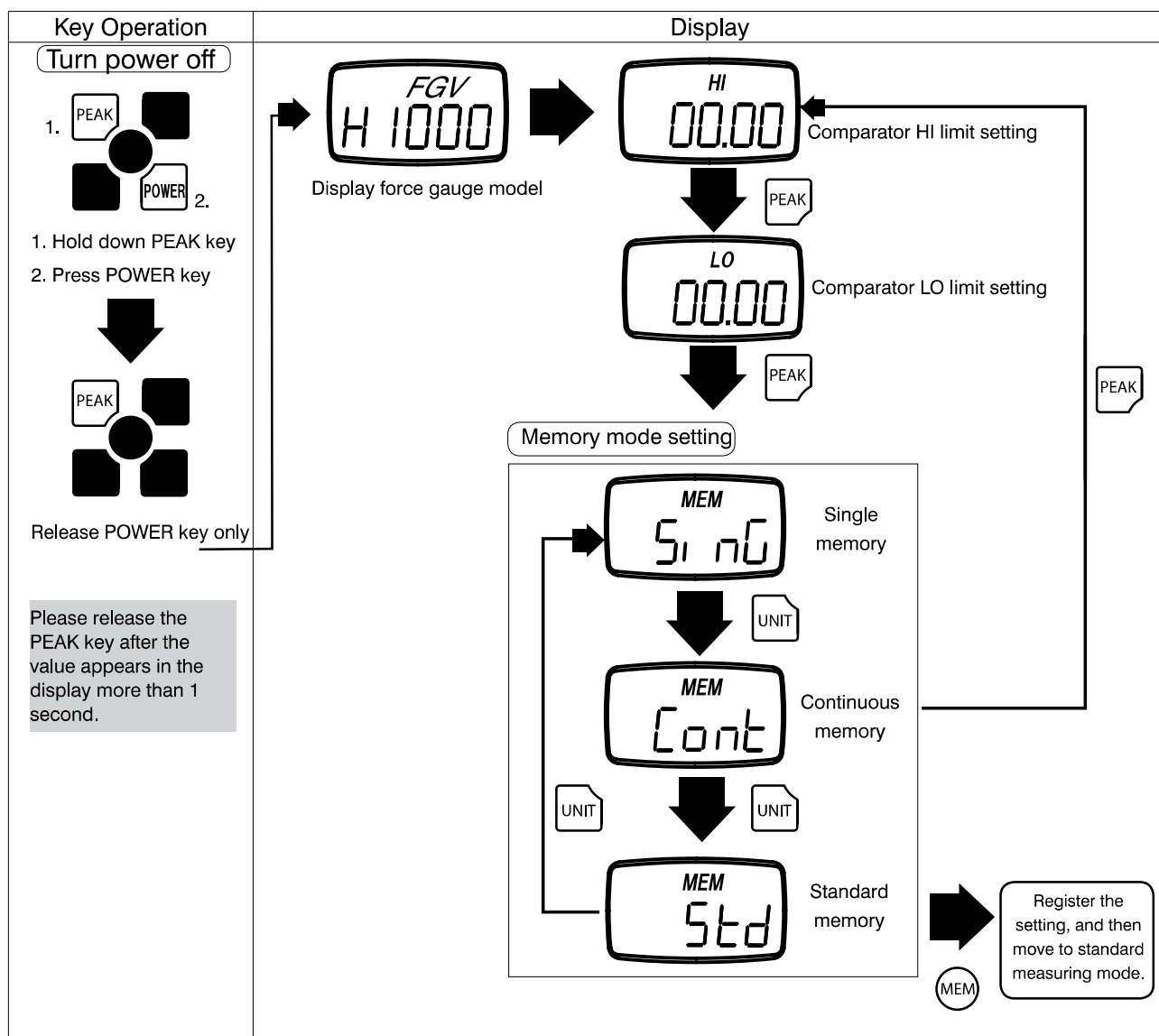

## 6.6.2. Storing data

Store the data at setting memory mode (single memory, continuous memory, standard memory).

### 6.6.2.1. Continuous memory mode

1. During the standard measuring mode, press MEM key. "M" will blink, unit starts to record. Press MEM key, measurement will cease, then display of the unit is changed from M into the unit.
2. When the memory reaches the 1000th recorded entry, "FULL" appears on the display. The recording is finished and will move to the standard measuring mode.

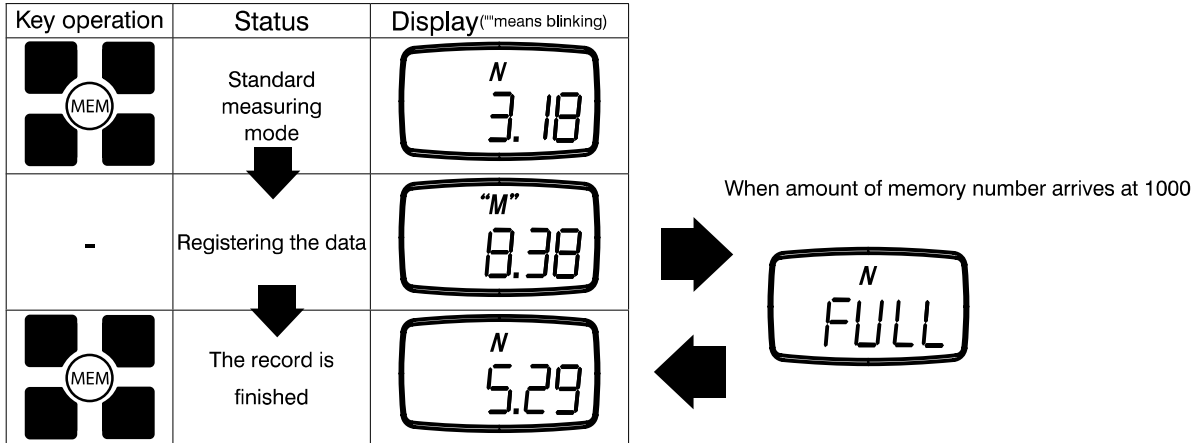

### 6.6.2.2. Single memory mode

1. During the standard measuring mode, press MEM key. "M" turns on at the unit display and one data is recorded.
2. If 100 data points are recorded, "FULL" appears for 1 second at the value display and returns to standard measurement mode.

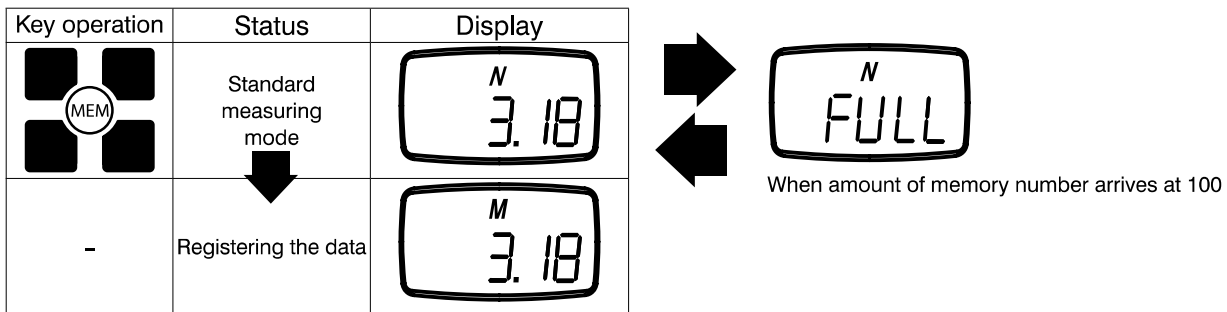

### 6.6.2.3. Standard memory mode

Press MEM key during standard measuring. "M" blinks at the unit display designating that max., min., and peak values are being recorded. Press MEM key again to finish measurement. Display of the unit returns to the standard display.

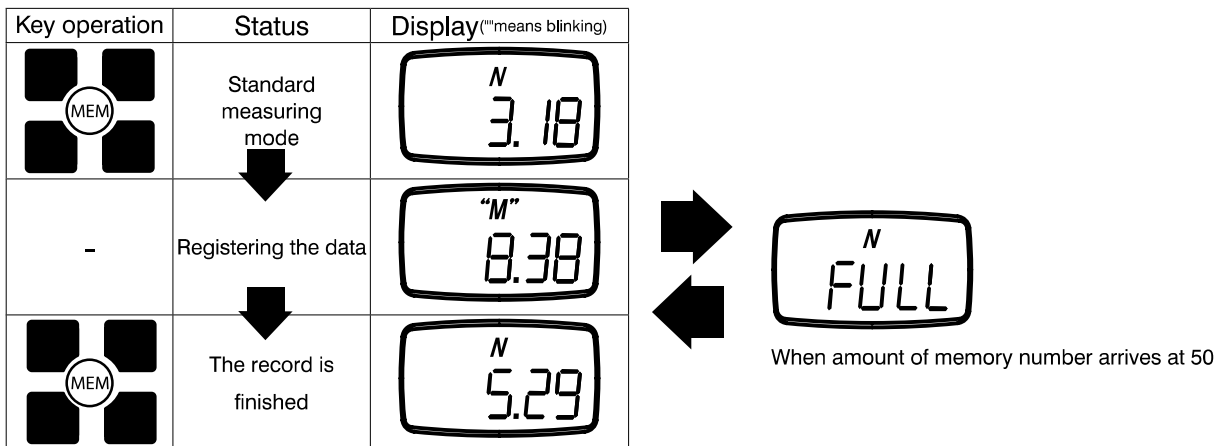





## 6.7. Recalling memory data

### 6.7.1. Continuous memory mode

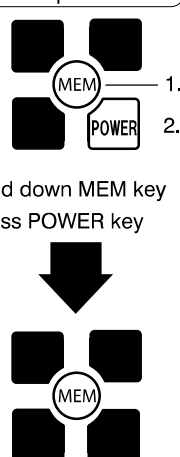
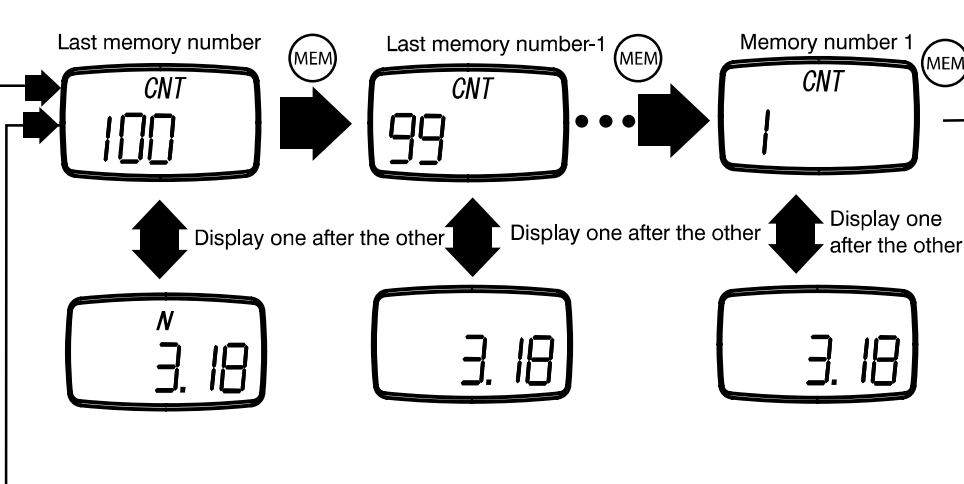
#### 6.7.1.1. Measuring memory data

1. Turn the POWER off. Press MEM key and hold, then press and release POWER. Release MEM when you see "CNT" on the display. The unit will alternate between showing the data block number, and the recorded measurement value of that block.
2. Press MEM to review the previous data block recorded.
3. Press UNIT to cycle through the available recorded statistics. In Continuous mode the available statistics are as follows: positive maximum value, negative maximum value, positive minimum value, negative minimum value, positive peak value, negative peak value, average value, standard deviation. This is covered in greater detail in the next section.
4. Press PEAK key to output the recorded memory data via RS-232C. Refer to section 7 regarding RS232C communication.

Key operation	Display
<p>Turn power off</p>  <p>1. Hold down MEM key 2. Press POWER key</p> <p>Release POWER key only</p> <p>Please release the MEM key after the value appears in the display more than 1 second.</p>	
	Delete the data when last memory data is displayed.
	Display the statistics memory data.
	Output the memory data with RS-232C, and then move to standard measuring mode.
	Finish display of the memory data. (Turn the power off)

## 6.7.1.2. Statistics memory data



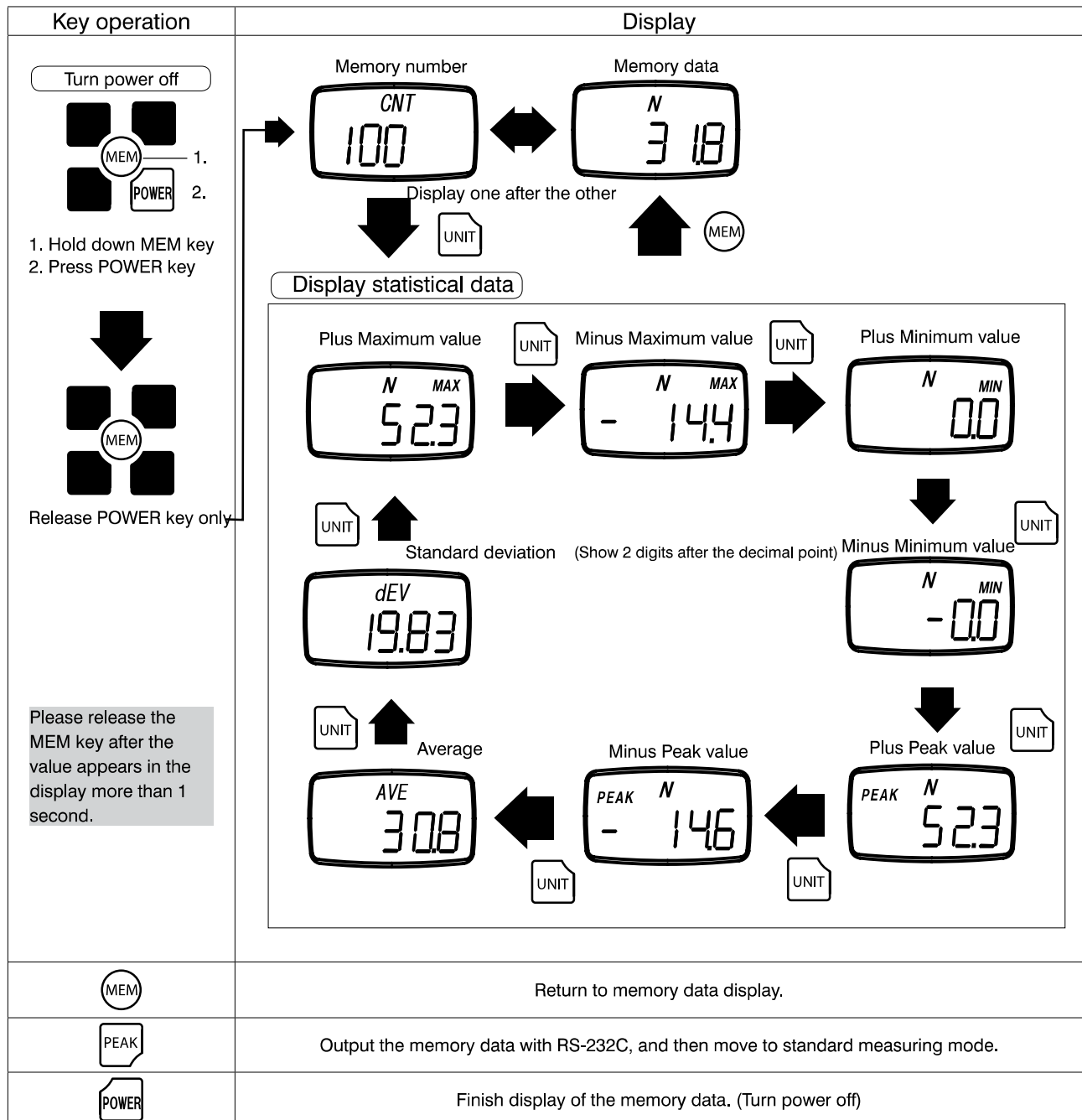

1. When in memory mode, UNIT will cycle through the available statistics data.
2. Each press of UNIT will switch between the following items: positive maximum value, negative maximum value, positive minimum value, negative minimum value, positive peak value, negative peak value, average value, standard deviation.
3. Press MEM to exit to the recorded measurement values.
4. Press PEAK key to output the recorded memory via RS-232C. Refer to section 7 regarding RS232C communication.

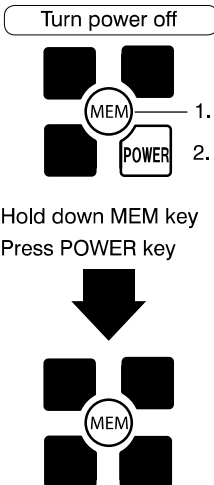
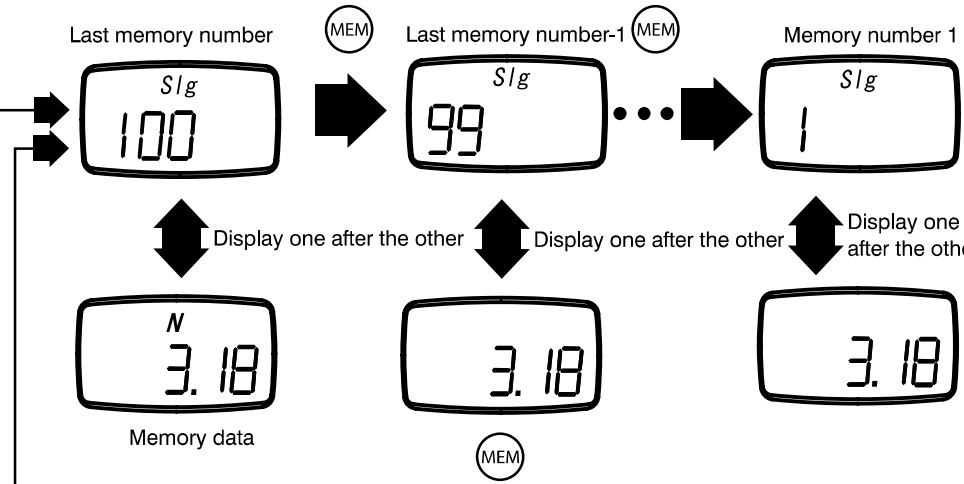

## 6.7.2. Single memory mode

### 6.7.2.1. Measuring memory data

1. Turn POWER off. Press MEM key and hold, then press and release POWER. Release MEM when you see "Slg" on the display. The unit will alternate between showing the data block number and the recorded measurement value of that block.
2. Press MEM to review the previous data block recorded.
3. Press UNIT to cycle through the available recorded statistics. In Single mode the available statistics are as follows: positive maximum value, negative maximum value, positive minimum value, negative minimum value, average value, standard deviation. This is covered in greater detail in the next section.
4. Press PEAK to output the recorded memory via RS-232C. Refer to section 6.2 regarding RS232C communication.

Key operation	Display
<p>Turn power off</p>  <p>1. Hold down MEM key 2. Press POWER key</p> <p>Release POWER key only</p>	 <p>Slg 100 → Slg 99 → ... → Slg 1</p> <p>Memory data: N 3.18, Slg 3.18, Slg 3.18</p> <p>Display one after the other</p>
<p>Please release the MEM key after the value appears in the display more than 1 second.</p>	
	Delete the data when last memory data is displayed.
	Display the statistics memory data.
	Output the memory data with RS-232C, and then move to standard measuring mode.
	Finish display of the memory data. (Turn power off)

## 6.7.2.2. Statistics memory data



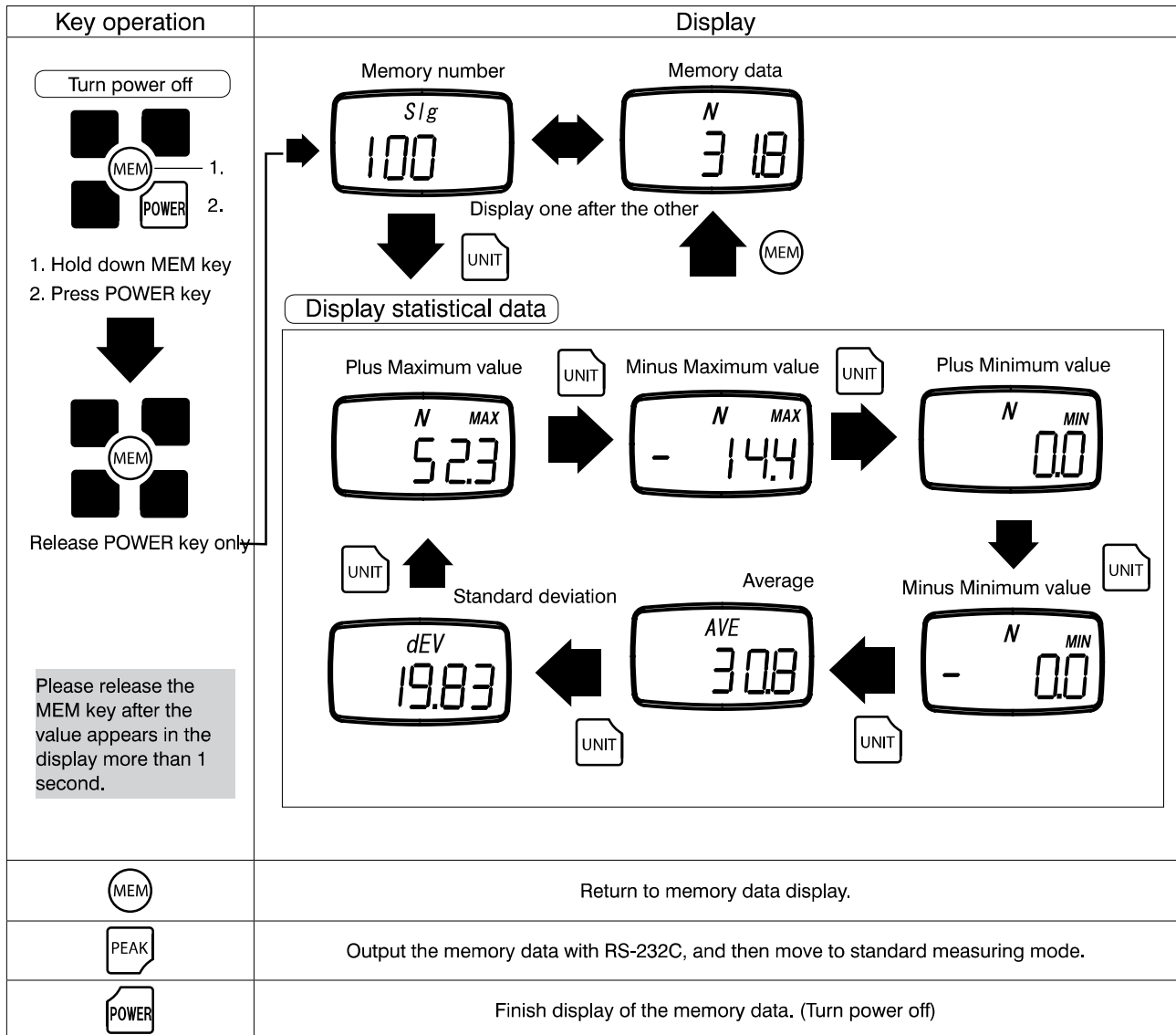

1. When in memory mode, UNIT will cycle through the available statistics data.
2. Each press of UNIT will switch between the following items: positive maximum value, negative maximum value, positive minimum value, negative minimum value, average value, standard deviation.
3. Press MEM to exit to the recorded measurement values.
4. Press PEAK key to output the recorded memory via RS-232C. Refer to section 6.2 regarding RS232C communication.

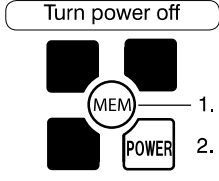
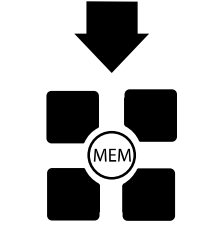
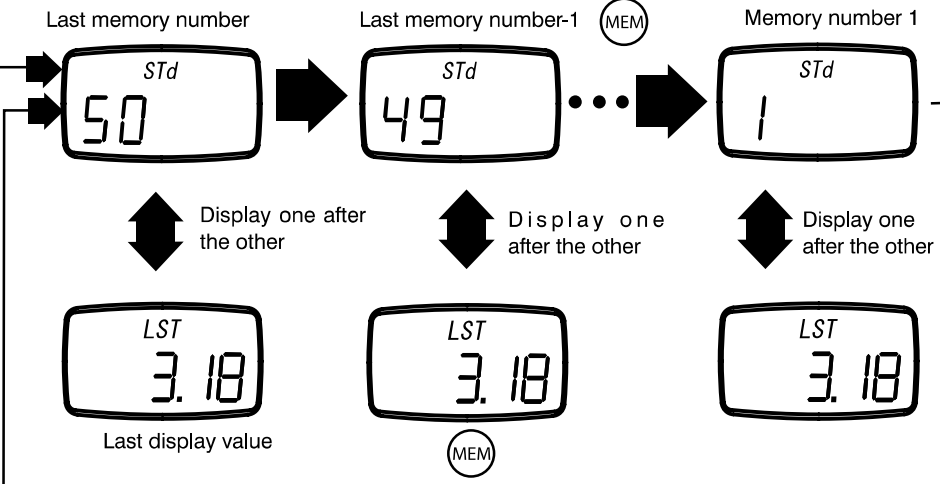

## 6.7.3. Standard memory mode

### 6.7.3.1. Measuring memory data

1. Turn the Power off. Press MEM and hold, then press and release POWER. Release MEM when you see "STd" on the display. The unit will alternate between showing the data block number, and the recorded measurement value of that block.
2. Press MEM to review the previous data block recorded.
3. Press UNIT to cycle through the available recorded statistics. In standard mode, the available statistics are as follows: positive maximum value, negative maximum value, positive minimum value, negative minimum value. This is covered in a greater detail in the next section
4. Press PEAK to output the recorded memory via RS-232C. Refer to section 7 regarding RS232C communications.

Key operation	Display
<p>Turn power off</p>  <p>1. Hold down MEM key 2. Press POWER key</p>  <p>Release POWER key only</p> <p>Please release the MEN key after the value appears in the display more than 1 second.</p>	 <p>STd</p> <p>Last memory number 50</p> <p>STd</p> <p>Last memory number-1 49</p> <p>MEM</p> <p>Memory number 1 1</p> <p>STd</p> <p>STd</p> <p>LST</p> <p>3.18</p> <p>Last display value</p> <p>LST</p> <p>3.18</p> <p>MEM</p> <p>LST</p> <p>3.18</p> <p>Display one after the other</p> <p>Display one after the other</p> <p>Display one after the other</p>
	Delete the data when last memory data is displayed.
	Display the statistics memory data.
	Output the memory data with RS-232C, and then move to standard measuring mode.
	Finish display of the memory data. (Turn power off)

### 6.7.3.2. Statistics memory data

1. When in memory mode, UNIT will cycle through the available statistics data.
2. Each press of UNIT will switch between the following items: positive maximum value, negative maximum value, positive minimum value, negative minimum value, positive peak value, and negative peak value.
3. Press MEM to exit to the recorded measurement values.
4. Press PEAK key to output the recorded memory via RS-232C. Refer to section 7 regarding RS232C communication.

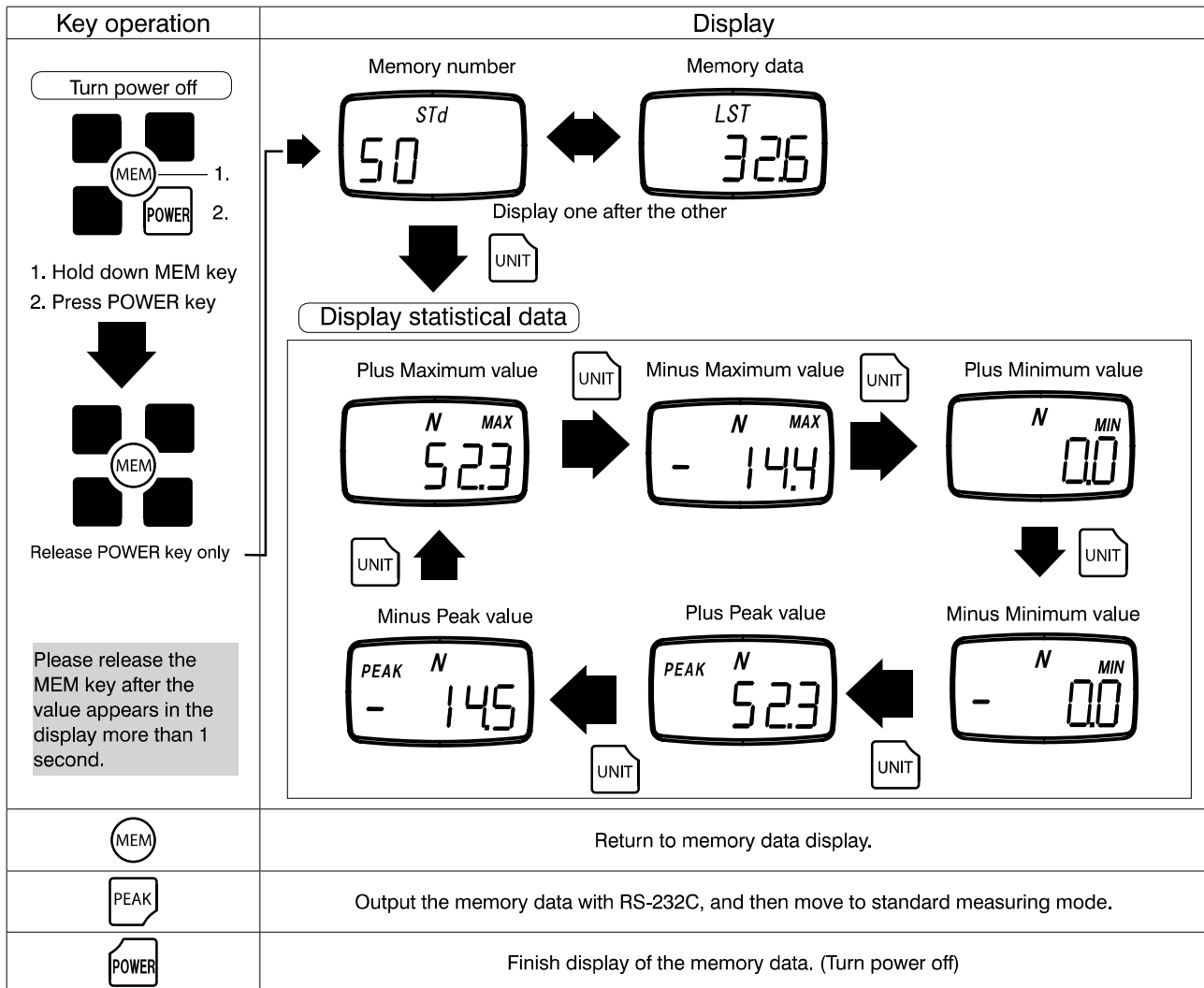

## 6.8. Erasing memory data

### 6.8.1. Erasing last data

1. The last recorded memory block may be erased by pressing ZERO while viewing the last data point.
2. If ZERO is pressed while viewing any other data point, the display will show "Err", and will not delete anything.

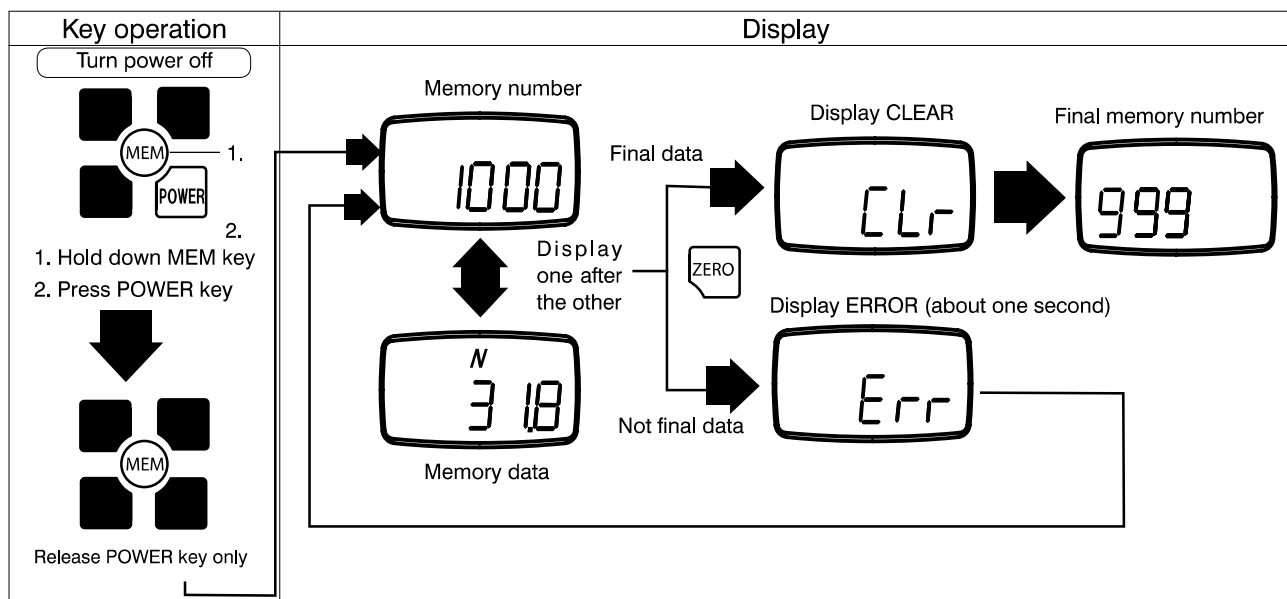

## 6.8.2. Erasing all memory data

- (1) When last memory data is displayed, all data will be erased if you press ZERO key for at least 5 seconds.
- (2) Display switches to standard measuring mode after showing "nonE" for one second at measuring display.
- (3) All memory data of current memory mode is erased.

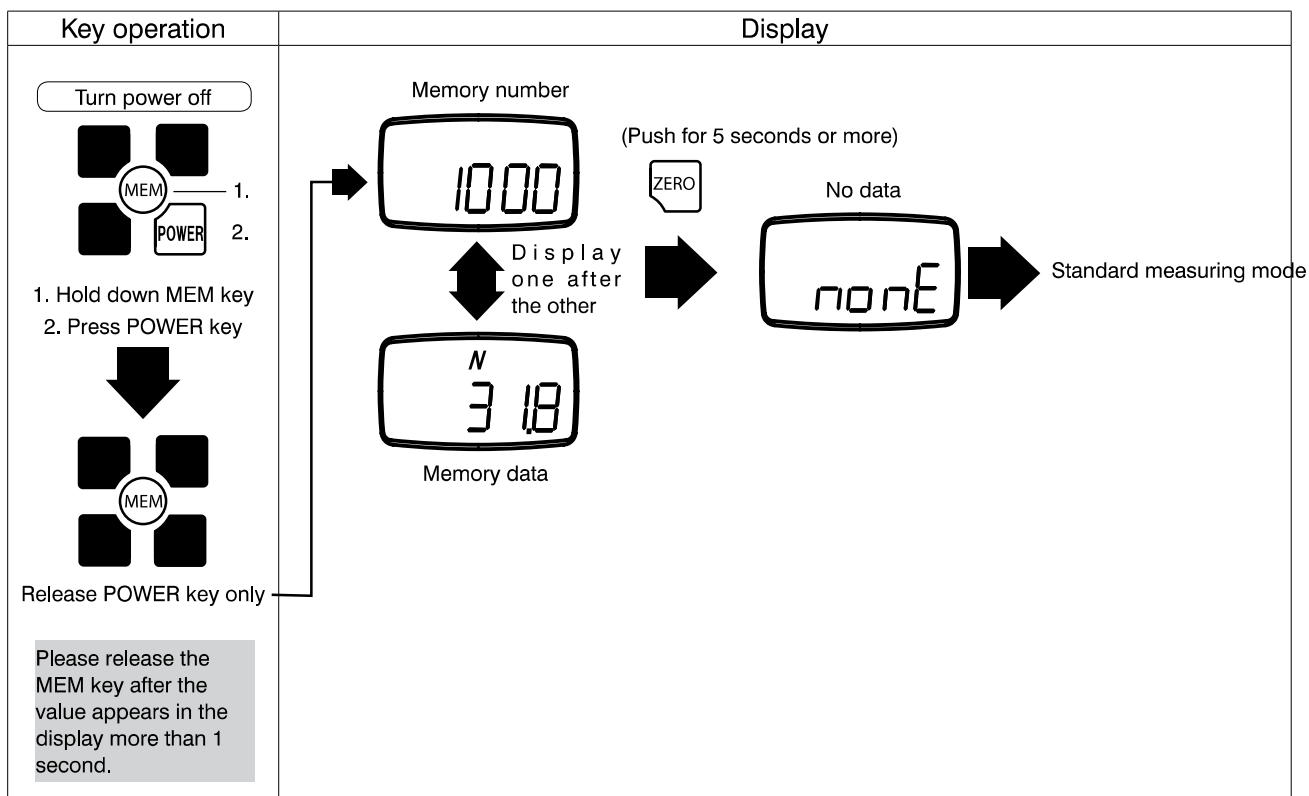

## 6.8.3. No memory data

Display shows "nonE" if switching to measuring memory data display mode.

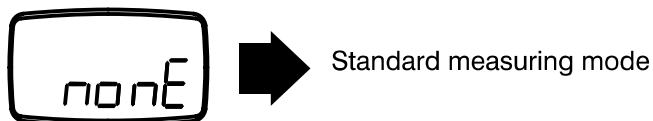

If no data is stored in memory, "nonE" is displayed for one second, the display will go back to the current measuring mode.

## 6.9. USB communication

If you connect the force gauge to a PC with the USB cable, you can download data to the PC from the force gauge of the current values being measured or from data that is stored in memory. See below on how to install the communication software ToriemonUSB.

### 6.9.1. Features of ToriemonUSB

You can take measuring data or memory data of force gauge directly into the excel seat by using "Toriemon USB" which is Excel add-in software. There you can analyze the recorded data or make graphs easily.

\*Microsoft Excel is registered as trademark of Microsoft Corporation in U.S.A.

### 6.9.2. Download ToriemonUSB

Please access our website [www.shimpointst.com](http://www.shimpointst.com) and download the software and manual. Please refer to the content of this instruction manual regarding the installing procedure of Torieom USB, function explanation, and operating procedure.

### 6.9.3. Precaution when using USB communication

Do not leave USB cable connected for extended period of time. If you leave USB cable connected, battery power tends to deplete even if the power of force gauge is off. (No problem for using AC adapter)

## 7.External Connection

### 7.1.Pin assignment

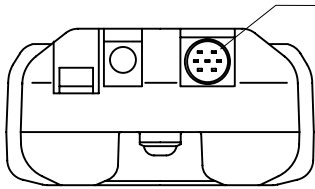

HR12 - 10RC - 10SDL made in Hirose is used for connector.

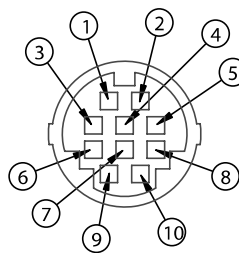

Pin Number	Signal Name
1	Analog +
2	Analog GND
3	R x D (RS-232C Received data) Host computer; FGP
4	Digital GND
5	Detection of Connection
6	T x D (RS-232C Transmitted data) FGP; Host computer
7	Connection disabled *1
8	Compression overload / LO output of comparator *2
9	Tension overload / HI output of comparator*2
10	Common of overload / comparator

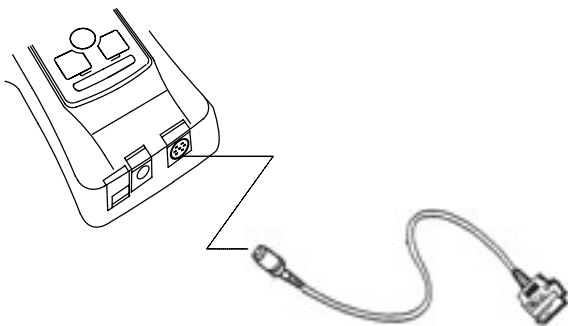

RS-232C communication cable: 2 m (Option)

\*1 Leave the pin (7) always unconnected.

\*2 Switch of overload output/comparator output can be set by external output setting (f06) of function mode.

## 7.2.RS-232C Output

You can operate this equipment from your PC if connecting it by using optional cable for RS-232C.

\* Cannot use USB communication and RS-232C communication at the same time.

### 7.2.1.RS-232C interface

Baud rate*	2400, 4800, 9600, 19200 bps
Length of data bit	8bit
Parity bit	None
Length of stop bit	1bit
Flow control	None

\* Please set baud rate according to RS-232C baud rate setting (f04) of function setting.

Default factory settings is 2400 bps. Please use your equipment as the above parameter.

Alphanumeric characters and carriage return (cr) of ASCII code is used for transmitting data.

## 7.2.2.RS-232C communication command

- Typical communication command

"cr" means carriage return.

Transmitting command from host computer to FGV	Content	Returning command from FGV	Explanation
AAcr	Tare	AAcr	
ABcr	Cancel of data transmission	ABcr	
ACcr	Switch to plus peak hold mode	ACcr	
ADcr	Switch to standard measuring mode	ADcr	
ALcr	Switch to minus peak hold mode	ALcr	
AEcr	Clear the plus/minus peak value to zero	AEcr	
AFcr	Switch the unit to kg	AFcr	
AGcr	Switch the unit to N	AGcr	
AHcr	Switch the unit to lb	AHcr	
AKcr	Switch the unit to oz	AKcr	
BAcr	Transmission request of one measuring data (measuring value at present)	BAcr NA□□□□□□cr	□□□□□□ : 6-digit value including sign, decimal point and 4-digit number
BBcr	Request for continuous transmission of measuring data (10 times/second)	BBcr NA□□□□□□cr	
BB1cr	Request for continuous transmission of measuring data (20 times/second)	BB1cr NA□□□□□□cr	
BB2cr	Request for continuous transmission of measuring data (50 times/second)	BB2cr NA□□□□□□cr	
BB3cr	Request for continuous transmission of measuring data (100 times/second)	BB3cr NA□□□□□□cr	
BCcr	Transmission request of model	BCcr NE□□cr	□□ : 2-digit number indicating model OC : FGV - 500HXY OD : FGV - 1000HXY
BDcr	Transmission request of unit	BDcr NH□cr	□ : one-digit number indicating unit 0 : N, 1 : kg, 2 : g, 3 : lb, 4 : oz
BEcr	Transmission request of plus peak value	BEcr NB□□□□□□cr	□□□□□□ : 6-digit value including sign, decimal point and 4-digit number
BFcr	Transmission request of minus peak value	BFcr NC□□□□□□cr	
In the communication with host computer, when FGV detect communication error, transmit the error command.		OBcr	Command format error (mistake command)
		OFcr	Flaming error
		OHcr	Overrun error

- Other communication command

Other than those above, a lot of communication commands are prepared.

## 7.2.3.Connection between FGV and PC

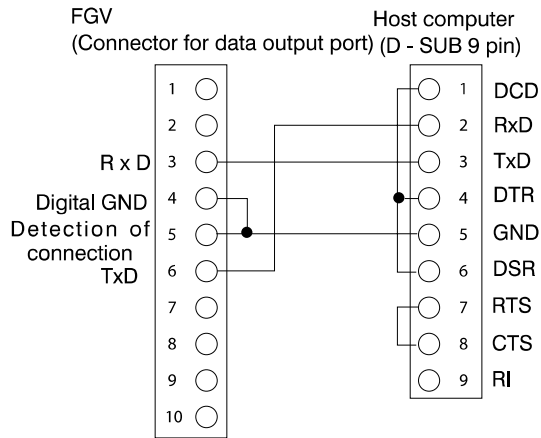

Please be sure to connect 5pin into 4 pin of digital GND when making cable for RS-232C on your own. It cannot be transmitted without this connection.

## 7.3.Analog output

Output  $\pm 1V$  for display range.

Output plus voltage when measuring value is plus (when compressing) and minus voltage when measuring value is minus (when tensioning). Output will be nearly 0 V if you press ZERO key and tare.

Output signal	$\pm 1V$ ( $\pm$ Range which display is possible)
Signal method	12 bit D/A convertor method
Output update	1000 times/second *
Load resistance	10 k $\Omega$ or more
Output accuracy	$\pm 50mV$

The analog output has a default update rate of 1000 times/second. The output voltage is linearly scaled so that the current zero point of the gauge corresponds with 0V, and so that 1V corresponds with 100% of the gauge's rated capacity. This means that the tare function, or any change in the gauge's zero point, will change the maximum voltage shown before the gauge is overload.

When using analog cable (option), please plug the connector side of cable into connector for data output port of FGV and connect red banana plug into plus and black banana plug into minus.

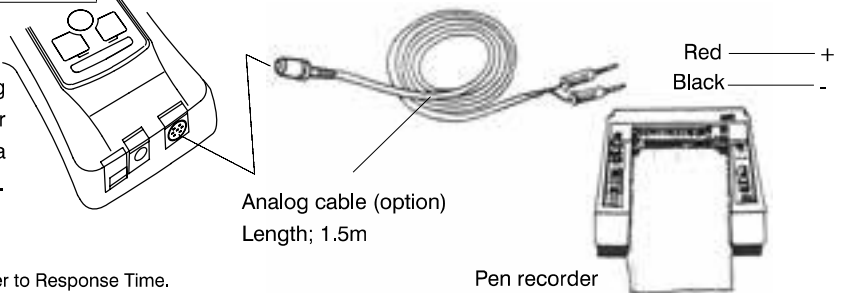

\* Depending on the Response Time setting (f05). Refer to Response Time.

## 7.4.Overload/Comparator output

Output overload/comparator signal.

Switch of output overload/comparator signal is set by external output setting (f06) function mode.

### • I/F Circuit

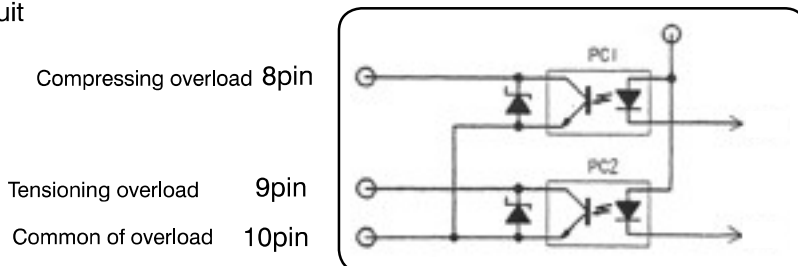

Compressing overload 8pin

Tensioning overload 9pin

Common of overload 10pin



Maximum allowance voltage DC 30V / current 5mA

Please connect the power and load to avoid going over maximum allowance.

### • Overload output

When the overload condition is triggered, the corresponding overload output turns on. This can be used to stop a motorized test stand, or an alarm to prevent damage from accidental overload.

When compression overload occurs photo-couple 1 (PC1) turns on, and allows current to flow between Pin 8 and 10.

When tension overload occurs photo-couple 2 (PC2) turns on, and allows current to flow between Pin 9 and 10.

If no overload condition exists, PC1 and PC2 should be closed, and will not allow current flow.

Overload occurs at about 120% of the gauge's rated capacity. This includes any weight zeroed during any tare operation.

### Comparator Output

When the LO limit is reached photo-couple 1(PC1) turns on, and allows current to flow between pins 8 and 10.

When the HI limit is reached, photo-couple 2(PC2) turns on, and allows current to flow between pins 9 and 10.

Refer to section regarding the activation and setting of comparator limits.

## 8. Signal Connector

### 8.1. Pin assignment

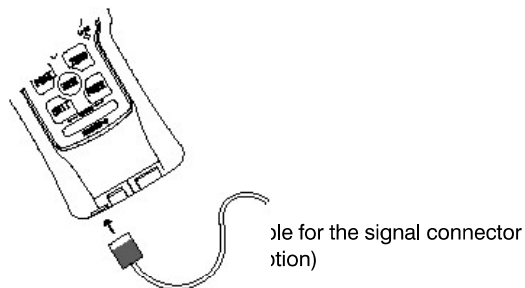
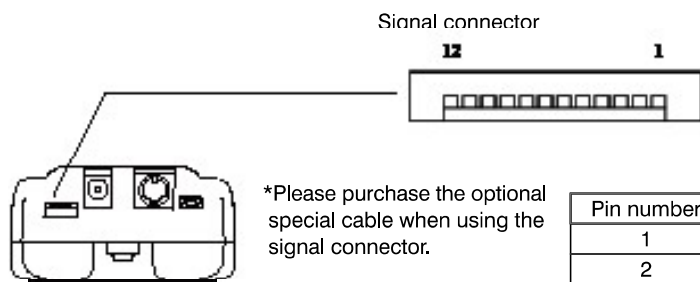

Pin number	Signal name	
1	REQ signal	Digimatic
2	READY signal	
3	CLK signal	
4	DATA signal	
5	Comparator upper limit output	Comparator
6	Comparator OK output	
7	Comparator lower limit output	
8	ZERO signal input	Input signal
9	HOLD signal input	
10	PEAK signal input	
11	Common for comparator output	
12	GND	

### 8.2. Mitutoyo Digimatic Output

Available to output one measuring data to the device (printer) provided Mitutoyo Digimatic communication. When the peak or hold mode are ON, just one hold data is outputted.

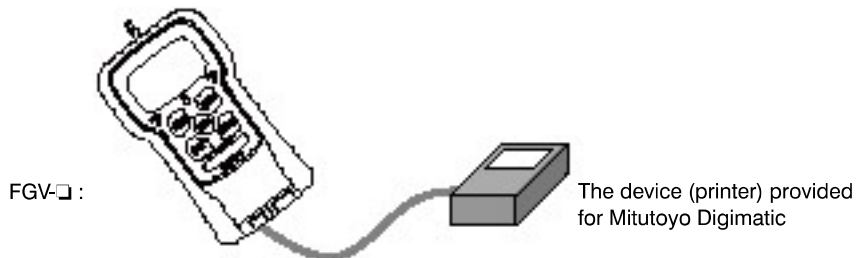

\*In function setting: f06, need to be set to "Ser".  
If setting is "Ser", you cannot communicate with Digimatic.  
\*Please make the connector to meet the device.

### 8.3 Comparator output

Doing comparator output.

• I/F circuit diagram

Comparator max output  
5pin  
Comparator OK output  
6pin  
Comparator Min output  
7pin  
Common  
11pin

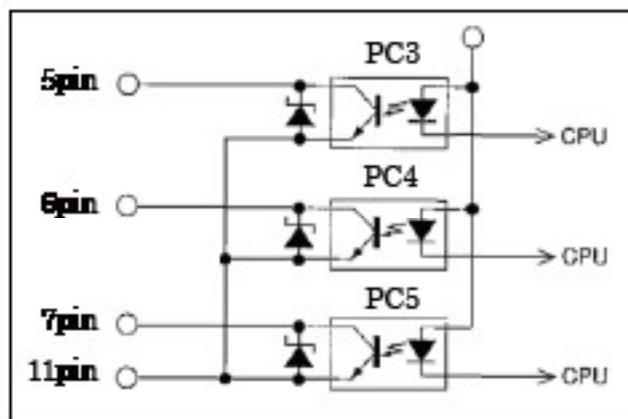

• Comparator output

When a comparator max output is ON, the photo coupler of PC3 is turned on and current flows.

When a comparator OK output is ON, the photo coupler of PC4 is turned on and current flows.

When a comparator min output is ON, the photo coupler of PC5 is turned on and current flows.

Please refer to "5.5. Comparator" for the details (the setting method of comparator upper limit and a lower limit, the judgment conditions of a comparator) of a comparator function.

## 8.4 External input signal

By an input signal from the outside, it is possible to perform tare influence (ZERO signal input), the hold of a measurement value (HOLD signal input), and the change to a peak operation mode (PEAK signal input).

### • Input circuit

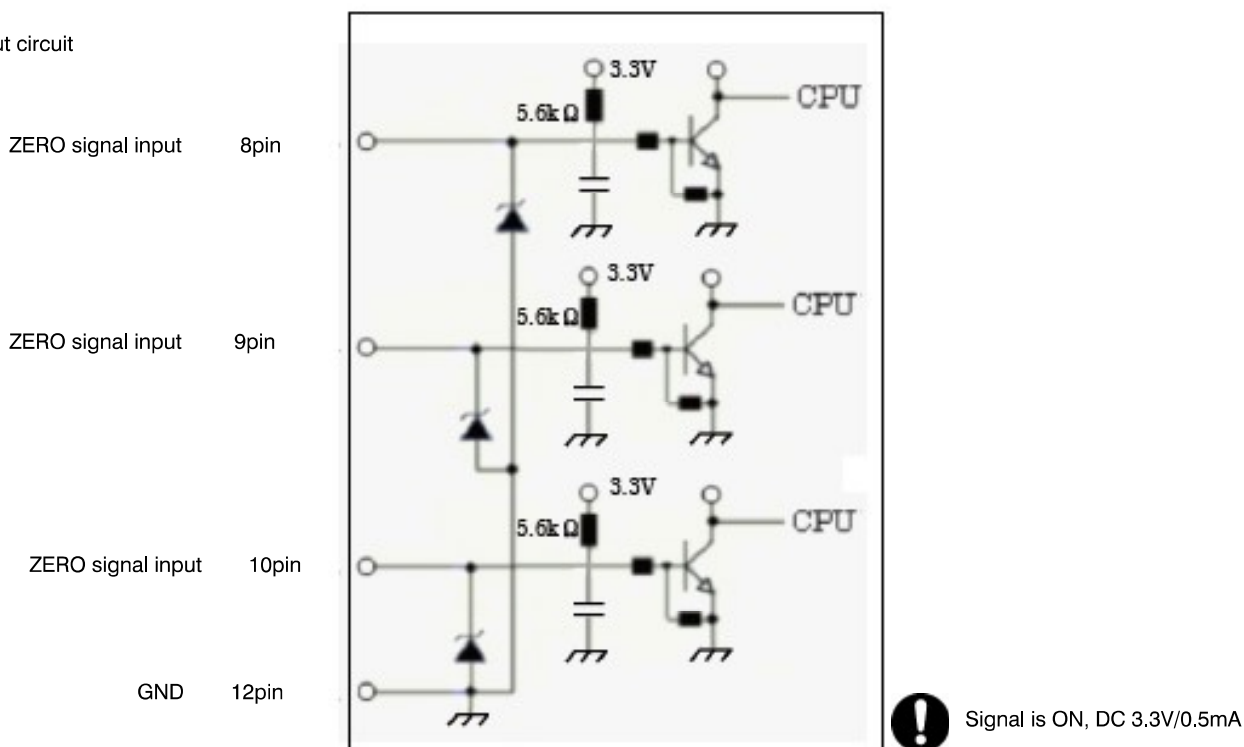

### • Signal input

#### 1. ZERO signal input

Tare and peak reset are performed when ZERO signal input

pin (8 pin) and GND (12 pin) is changed from OPEN to CLOSE (ZERO signal is ON).

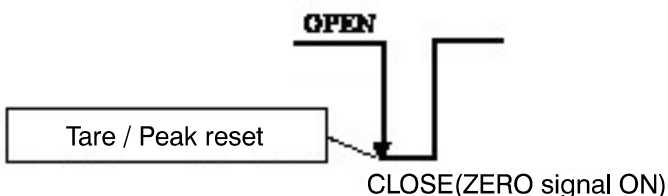

#### 2. HOLD signal input

HOLD signal is ON when HOLD signal input pin (9 pin) and GND (12 pin) is changed from OPEN to CLOSE.

The display number doesn't change while HOLD signal is ON. And "Hld" is shown on the sub display.

When HOLD signal is OFF, the display is back to the measuring mode.

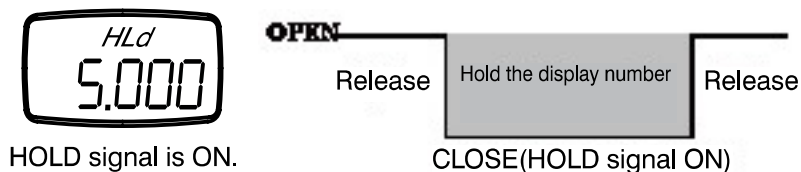

#### 3. PEAK signal input

PEAK signal is ON when PEAK signal input pin (10 pin) and GND (12 pin) is changed from OPEN to CLOSE.

While PEAK signal is ON, if the function setting (f07) is +PEAK, the measuring mode is + peak mode. If -PEAK, the measuring mode is - peak mode. When the PEAK signal is OFF, it's the normal measuring mode.

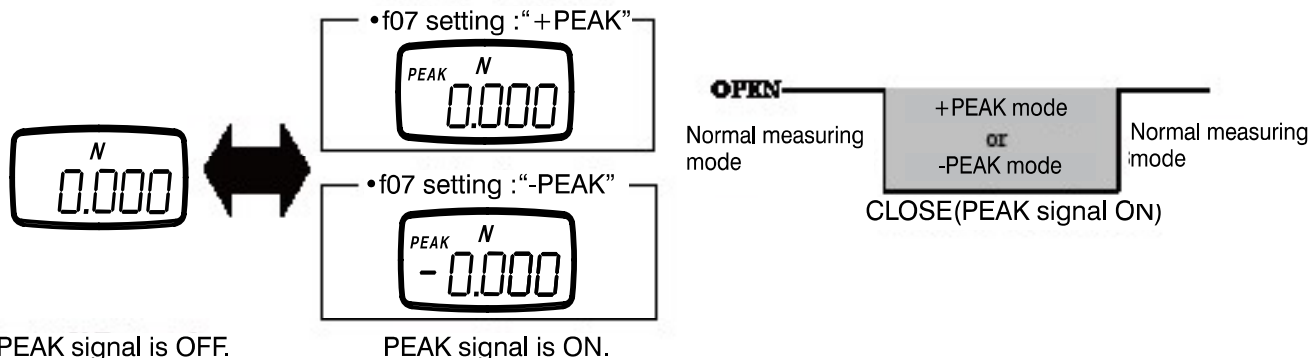

\* If the function setting (f07) is "nonE", PEAK signal is no effect. Cannot switch the measuring mode by using PEAK signal.

## 9.Frequently – asked questions

### 9.1.Troubleshooting

Questions	Cause	Presumable reason	Procedure
When turning on power, “OVR” is displayed even if not applying load and cannot be cleared by pushing ZERO key.	It is possible that internal loadcell is broken.	Unit was dropped or overloaded.	Contact a dealer for repair
Low bat displays even after the unit was charged for more than one day.	Voltage of battery is low.	<ul style="list-style-type: none"> <li>• End of battery life</li> <li>• Breakdown of battery</li> <li>• Breakdown of charging</li> </ul>	Contact a dealer for repair
It doesn't display anything even if pressing POWER Key.	Battery is weak.	Voltage of battery is lower.	Please charge a battery.
	“BAT” isn't displayed on LCD even if charging up.	<ul style="list-style-type: none"> <li>• Breakdown of battery</li> <li>• Breakdown of internal circuit</li> <li>• Breakdown of AC adapter</li> </ul>	Contact a dealer for repair.
The value becomes “0” automatically when measuring small value near 0.	You can use tracking to prevent the fluctuation of the measuring value near “0”.	Tracking is on.	Please set tracking off. (Refer to “4.5.Tracking”)
Value changes if you change the direction of force gauge.	This is not breakdown. This equipment is measuring the empty weight of sensor on its own.	Sensor or tools can add weight	Push ZERO key after setting the direction to measure and clear the measuring value.
Although I downloaded “Toriemon”, it doesn't work even if connecting force gauge.	-	Since “Toriemon” is software for RS-232C transmission, it doesn't respond to USB transmission.	Please download “Toriemon USB” and use it.

### 9.2.Technical issue

Questions	Explanation	Reference
How long does rechargeable battery (Nickel hydride battery) last?	Enable to use 500 times or more by complete electric discharge. It depends on the status of use.	Please charge battery after discharging electricity until “LO BAT” is displayed at LCD.
Why are there various rating capacities?	The value is more accurate when measuring near rating as much as possible.	It is ideal to use this equipment with 50% rating or more.
Why does measuring data show variations?	Although there are many reasons, the measuring value is affected by vibration if operated by hand.	Fluctuation will be reduced when using handle or stand.
How does biased loading affect accuracy?	Although it depends on the angle, you cannot measure accurate value with biased loading.	
How do you handle ISO calibration?	Measure the load value with certified weights.	Weight with traceability is necessary.
Please tell easy test methods which user can.	Please hang the weight which is clear.	
Can user exchange battery?	User cannot exchange battery.	Ask our dealers to assist you with battery replacement.
Do you have CAD data?	Yes.	Please contact our dealer.
Is it possible to use in water?	No. It is not waterproof structure.	Please pay attention not to pour water.

## 10.Support

### 10.1.Repair and Calibration

We recommend calibrating regularly for keeping up the accuracy of force gauge. Nidec-Shimpo provides calibration services. Contact for details.

### 10.2.Warranty

Nidec-Shimpo Corp. warrants, to the original purchaser of new products only, that this product shall be free from defects in workmanship and materials under normal use and proper maintenance for two years from the date of original purchase.

# 11. Dimensions

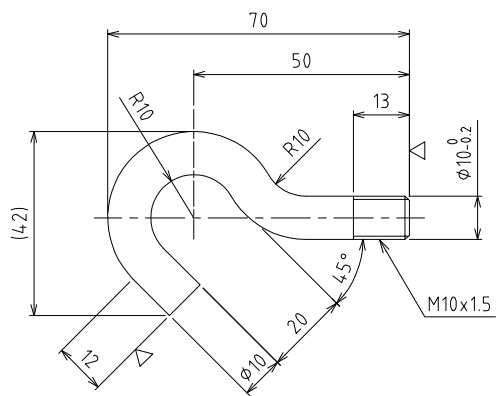
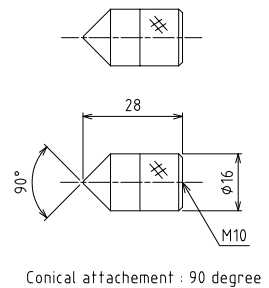
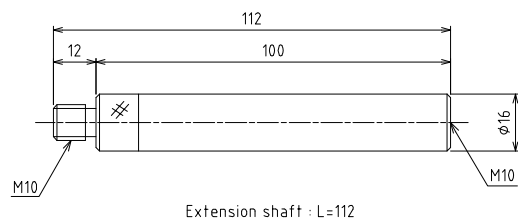
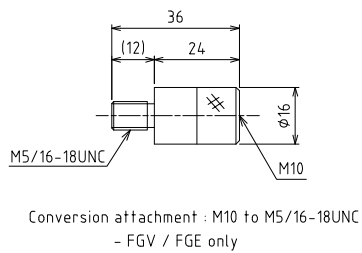
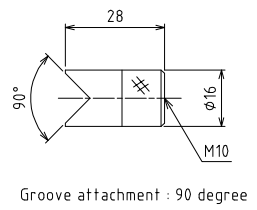
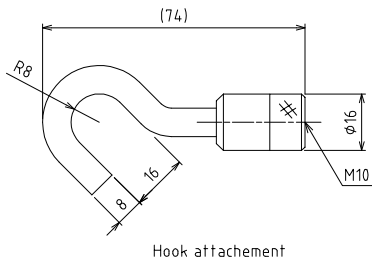
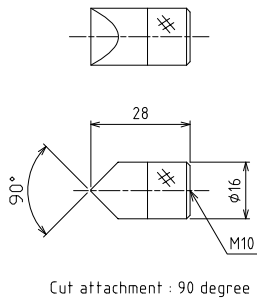
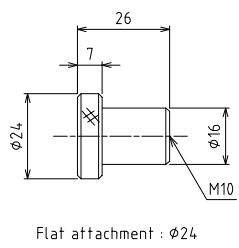
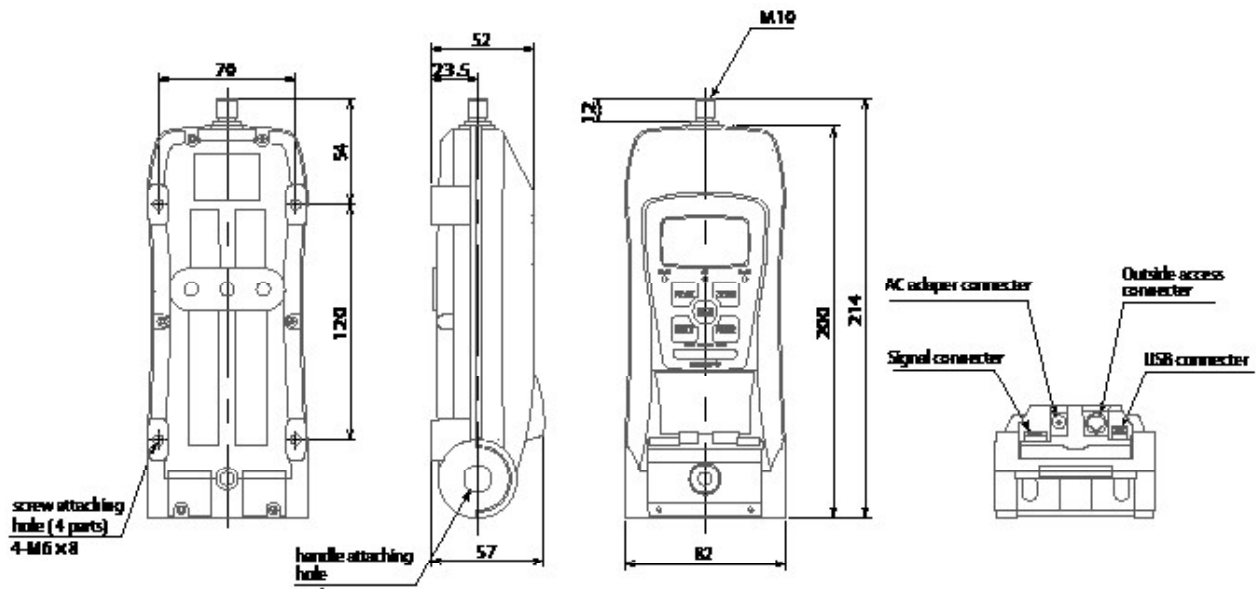

**SEALS USA, Inc.**

---

**Instruments Division**

**Tel: (630)924-7138**

**Email: [support@seals-usa.com](mailto:support@seals-usa.com)**